

## Modern Bracket with Outlet

US-WB983

# Installation Instructions



## Introduction

**IMPORTANT:** Please read these instructions carefully before beginning and retain for future reference.

We do not accept responsibility for any problems that may occur through incorrect installation.

Before beginning installation, check for any damage that may have occurred during transport.

**Note: Damage claims cannot be made during or after installation.**

## Installation notes

The installation must comply with all plumbing codes including local codes and be installed by a licensed plumbing contractor.

**IMPORTANT!** Before installation it is essential that the supply pipes are thoroughly flushed in order to remove any remaining debris, solder or other impurities. Failure to carry out this procedure can cause problems or damage to the working of the bracket. Installing shut-off valves on incoming supply lines is recommended for ease of maintenance.

**Turn off the main water supply before connecting to any existing pipework or doing any maintenance.**

**WARNING! Please check for any hidden pipes and cables, electric or otherwise, before drilling holes in a wall or floor.**

## Dimensions

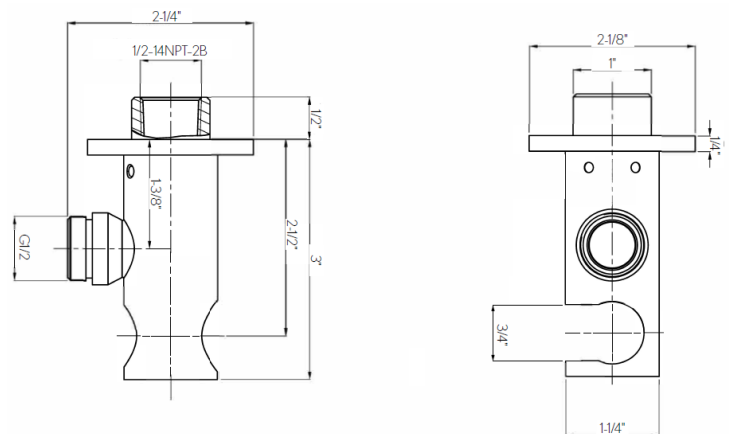

## Tools required

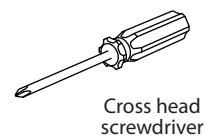
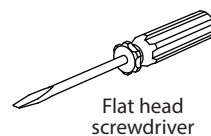
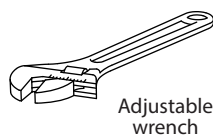
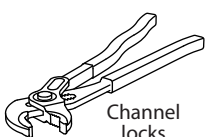

# 1 Installation

With the main water supply turned off:

- Connect the elbow connection to the mixed feed water supply, use teflon tape to achieve a watertight seal.
- Make sure the cover plate is placed over the outlet and bracket.
- Insert the outlet and bracket on to the elbow connection and fix with the set screws. Tighten the screws with the hexagonal key, then fit the screw covers.
- Apply a narrow bead of clear silicon sealant around the back edges of the cover plate and carefully press into position.

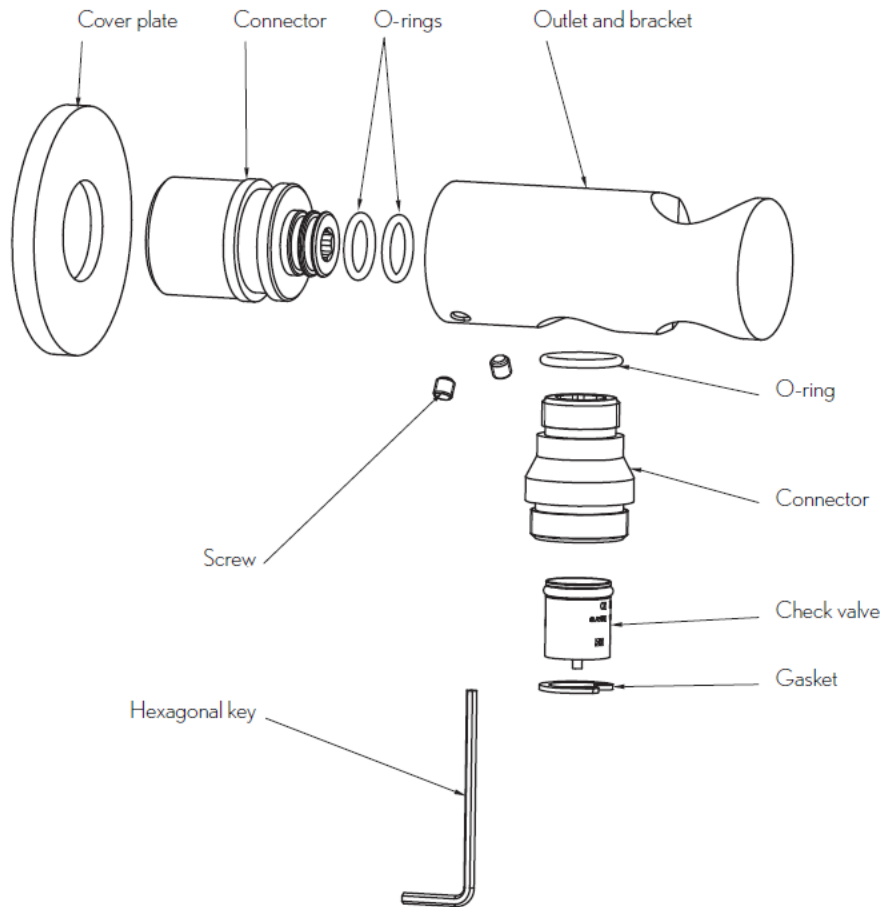

## 2 Cleaning Instructions

Rinse away any traces of soap and gently dry with a clean, soft cloth after each use. Rinse completely with water and dry any overspray. This will maintain the finish and avoid water spotting.

To remove mineral deposits, use a 50/50 solution of white vinegar and water. Do not allow the solution to soak on the product. Simichrome Polish® contains a protective film to enhance maintenance and is helpful in preventing water spot buildup. Follow instructions to ensure optimum results.

Never use an abrasive material such as a brush or scouring pad to clean the surface. The use of abrasive cleaners, cleansers or disinfectants will alter the surface finish and void the warranty.

Do not allow certain materials such as toothpaste, cologne, shaving cream, nail polish remover, vinegar, wine, drain and glass cleaners to remain on the surface. Prolonged contact will alter surface finishes and void the warranty.

**We DO NOT recommend using any household cleaners as many can cause damage to the finish.**

Please see the website for care instructions for specific finishes.

**Warranty:** This **Crosswater London** product is covered by a limited lifetime warranty. For full details, terms and conditions please visit our website.

For further information contact: **Crosswater London**, 393 Fortune Blvd., Milford, MA 01757

844-XWATER-1 (844-992-8371) tel: 508-381-0433 fax: 508-381-6068

**www.crosswaterlondon.com** Toll free number:

email: [technical@crosswaterlondon.com](mailto:technical@crosswaterlondon.com)