

Tools & equipment needed:

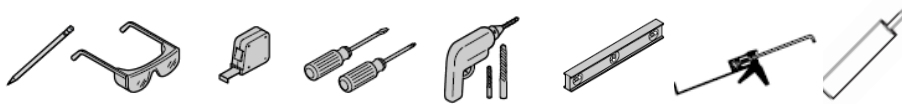

IMPORTANT - Advice and safety - Please read before installation

Please read these instructions carefully before starting installation and keep in a safe place for future reference.



Advice & Safety

Important! Risk of product damage. Do not modify the vanity. Doing so will compromise structural stability and warranty. This instruction manual contains information on how install the MPRO collection.

This product should only be installed by a suitably qualified plumber/installer. Should the installation be completed by a non-qualified person any product guarantee maybe considered invalid. Ensure the room is well heated and ventilated.

Note. This series comes in several sizes and one semi-column; the installation procedures remain the same. Observe all local building codes. Two people should install this product.

Warning! Please check for any hidden pipes or electrical cables before drilling holes in the floor or walls. Do not over tighten tap or waste fittings, doing so may result in damaging the basin.

This vanity series needs specific site preparation. Do not install vanities until all support framing and plumbing rough-ins have been completed and wall surface has been finished.

The vanity units CAN ONLY BE installed using the fitting brackets supplied. Before installing a wooden bathroom product into a new property extension or recently plastered room we strongly advise the building/room is completely dry, well ventilated and adequately heated prior to installation.

Secure the vanity to stud framing. When possible, provide 2X6 timber behind the finished wall for additional support. To ease installation, remove drawers from the vanity before fitting. Refer to the section in this guide for proper removal.

Save these instructions for future use and reference. An improper installation voids the warranty. Installed vanities cannot be returned. If you experience any problems with your vanities, contact your dealer or Crosswater directly.

INSTALLATION INSTRUCTIONS

Two-Drawer Vanity

Step 1

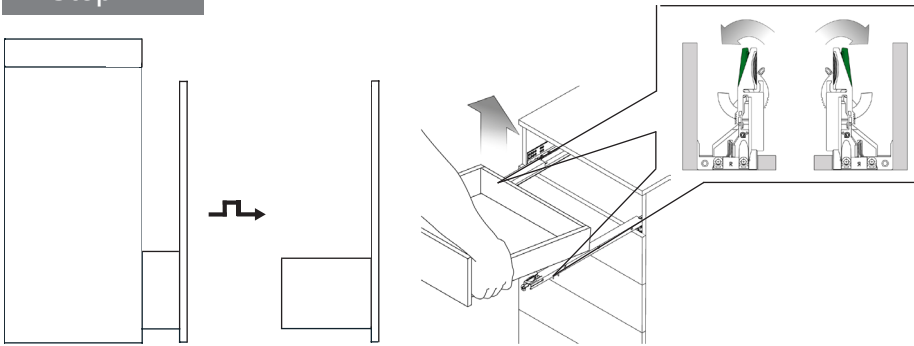

Pull out the drawer to its full extension by gently squeezing the locking levers outwards on both sides and pull the drawer off the runners at the front.

Step 2

Plan unit position

Decide on the position and height of the vanity. The recommended sink height is between 34" and 35" from floor to top of basin.

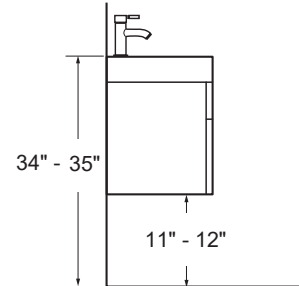

Step 3

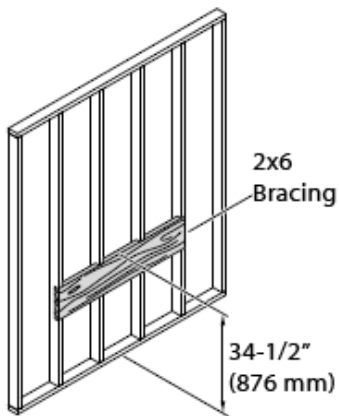

To properly support the weight of the vanity and basin, secure to stud framing or 2x6 bracing behind the finished wall.

When installing 2x6 bracing, front-notch the studs to ensure the bracing sits flush against the studs. The bracing should span the length of the vanity.

Consider for routing supply and drain piping for your desired sink.

IMPORTANT: To ensure proper support and alignment:
The finished wall must be straight and plumb.

Complete AND finish the wall decoration or tiling before vanity installation.

Step 4

a/ 24" Vanity

a/ 28" Vanity

a/ 39" Vanity

a/ 48" Vanity

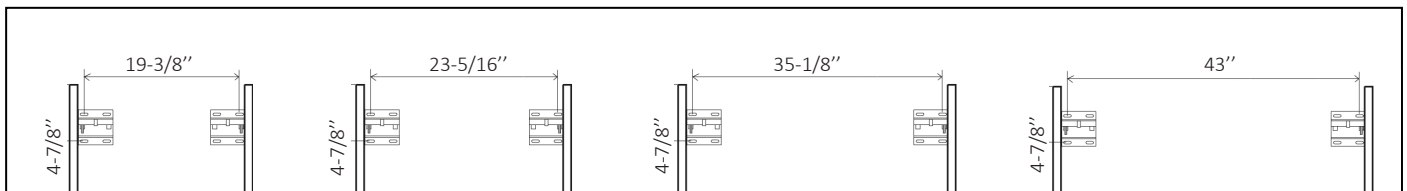

Step 5

Wall hanger installation

Place vanity in desired position on wall, mark wall hanger fixing points.
Drill 5/16" (Ø 8mm) holes.

Important: If the vanity unit and/or basin are not fitted level this may result in the basin not draining correctly.

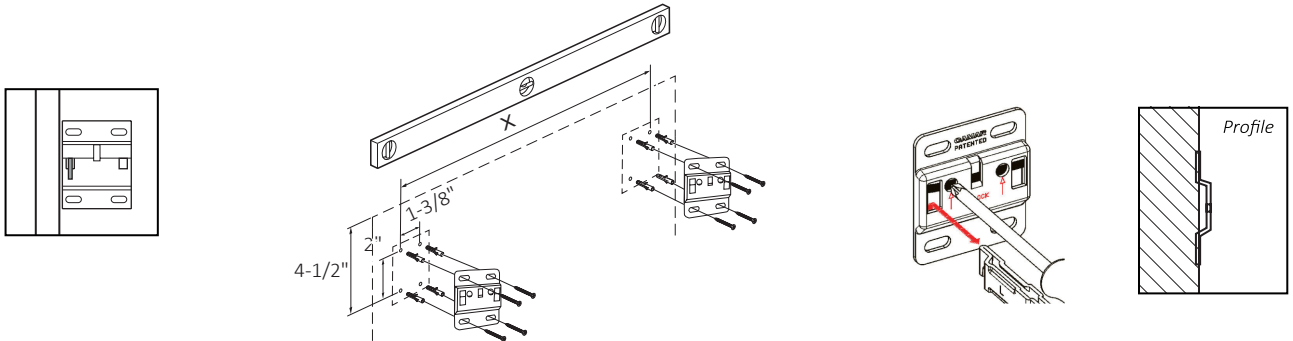

Step 6

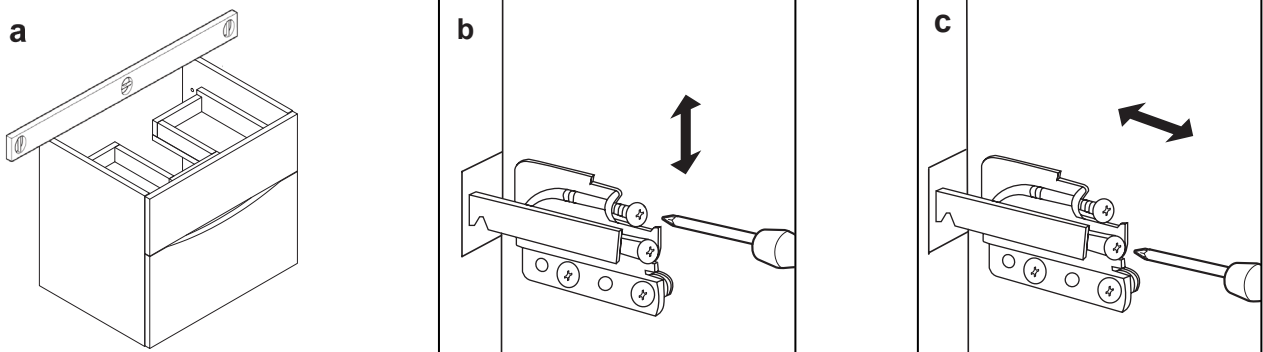

- a:** Check the vanity is level. If levelling is required, use a screwdriver to adjust the hanging position, as follows.
b: To lift or lower the unit, adjust the screw shown.
c: To move the unit closer or further from the wall, adjust the screw shown.

Step 7

Basin Installation

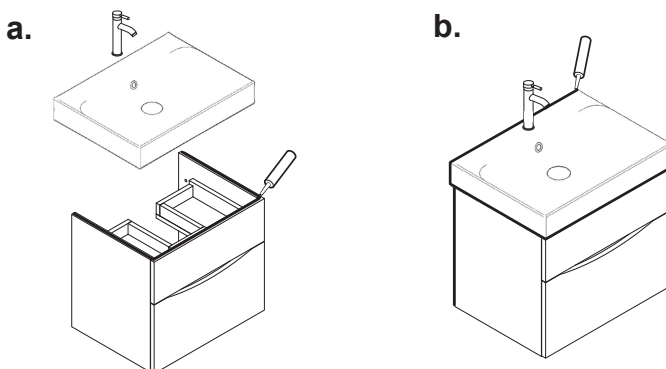

a: Carefully apply silicone to the top edges of the vanity.

b: Carefully position the basin down onto the vanity, ensure it is centrally positioned and flush at the back.

Connect faucet and drain in accordance with manufacturer's instructions. Apply silicone to the join between the worktop and wall, down sides of the unit and around the base of the basin.

Leave silicone dry for 24 hours.

Note: Basin drain and faucet fittings when over-tightened can create stress within the basin material which may in time cause the failure of the product. Drain fittings should be carefully bedded in silicone and the back-nut hand tightened an additional

quarter turn using a suitable spanner is sufficient to create the required water-tight seal. Care should also be taken when fitting the faucet to tap ledge in order to prevent similar stress-related failures.

Step 8

Re-fit drawers:

- 1: Pull drawer runners fully out.
- 2: Set the drawer down onto the runners.
- 3: Push the drawer fully in.

Test to make sure the drawers operate correctly and there are no obstructions behind the drawer.

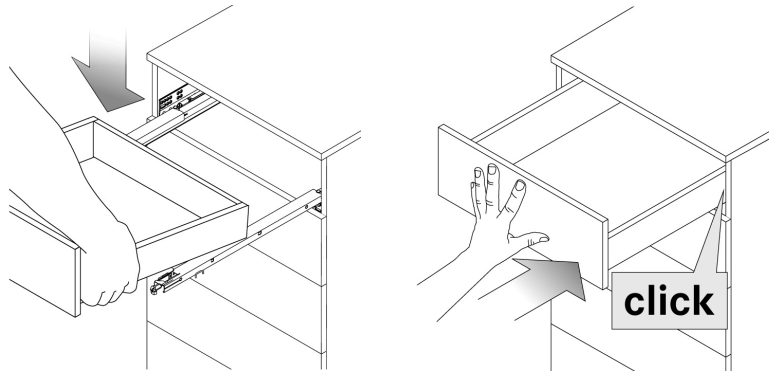

DRAWER RUNNER ADJUSTMENT - Grass Dynapro Soft-close

Step 1

Front height adjustment

Max. + 1/8"

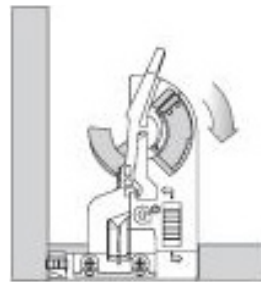
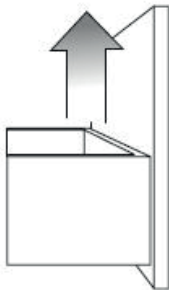

Step 2

Front tilt adjustment

Max. + 1/8"

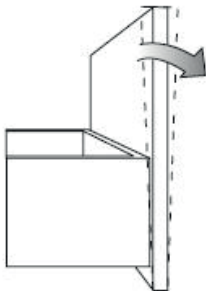

Step 3

Side adjustment

Max. \pm 1/16"

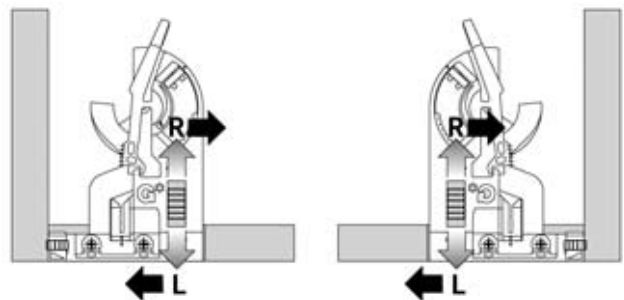
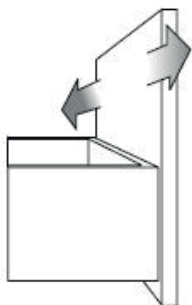

Step 4

Depth adjustment

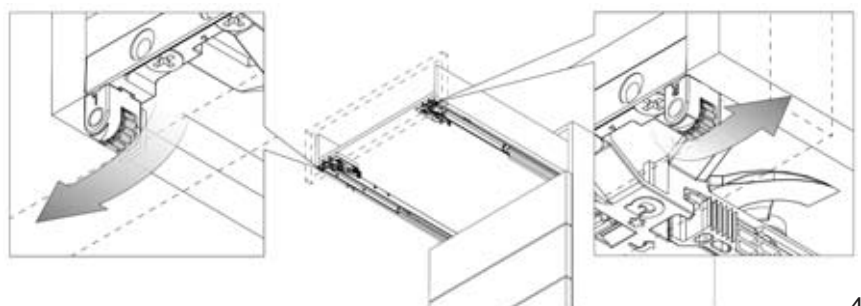
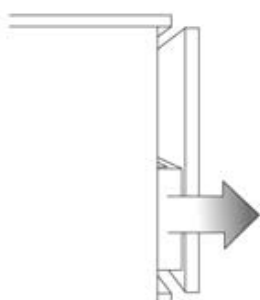

Care and Cleaning

To maintain your CROSSWATER product in perfect condition, consider the following in mind when caring for your product:

- Clean any spills immediately with a soft, damp cloth.
- Test cleaners in a discrete location first, such as the inside of a drawer, to ensure that there is no adverse reaction.
- Do not expose wood furniture to direct sunlight, drying heat sources or dampness.
- Dust frequently with a soft cloth in the direction of the grain.
- Use only products specifically made for cleaning wood. Avoid using oily polishes or waxes or products containing silicone.
- Do not use cleaning products containing bleach or abrasives, use only a damp cloth to clean.
- Paint pens and touch-up markers are available to conceal scratches on the painted surface. These products may be purchased from CROSSWATER London.

Every few months, remove built up dirt by cleaning surfaces with a soft cloth and a 50/50 solution of warm water and an ammonia-free detergent. Wipe clean with cloth dampened in warm water. Wipe dry.

THE CROSSWATER LONDON WARRANTY

Our commitment to quality & excellence

CROSSWATER LIMITED WARRANTY

The following are the terms and conditions of Crosswater London USA's ("Crosswater London's") exclusive written warranty. No warranty by any person in addition to or different from those made in this limited warranty shall be binding on Crosswater London.

LIMITED COMMERCIAL WARRANTY

Crosswater London products used commercially are warranted by Crosswater London to be free from manufacturing defects for a period of one (1) year from the date of acquisition by original purchaser. This limited warranty is subject to the "warranty exclusions and disclaimers" set forth opposite.

LIMITED RESIDENTIAL WARRANTY

Crosswater London warrants that it will, at its election, repair, replace or make appropriate adjustment for any product that proves defective in materials and/or workmanship under normal residential installation, use and service within the warranty period for that product as stated in the "Residential Warranty Periods" set forth below. This limited warranty is limited to normal domestic use only and excludes damage resulting from reasonable wear and tear, misuse, abuse, neglect, or improper installation, maintenance and repair. This limited warranty is provided to the original purchaser only and is not transferable. Labor charges incurred by the purchaser to repair, replace, install or remove any product are not covered by this warranty.

This limited warranty is subject to the "warranty exclusions and disclaimers" set forth opposite.

RESIDENTIAL WARRANTY PERIODS

All Crosswater London products are covered by a Limited Lifetime warranty except bath furniture (10 years), mechanical parts of toilets and ITD-5135 (5 years), and toilet seats (1 year).

FINISHES AND DRAINS

Limited Lifetime warranty on all finishes except living finishes and drains which are excluded from the warranty. Due to the nature of drain usage, there is no finish warranty on any drain product (including lavatory and bathtub drains).

WARRANTY EXCLUSIONS AND DISCLAIMERS

To the maximum extent permitted by law, Crosswater London makes no other warranty, express or implied. To the maximum extent permitted by law, Crosswater London expressly disclaims the implied warranties of merchantability and of fitness for a particular purpose, and all other obligations or liabilities on the part of Crosswater London. Under no circumstances shall Crosswater London's liability to buyer or any third party, whether in contract, in tort, under any warranty, in negligence or otherwise, exceed the purchase price paid for the product. In no event (including with respect to any implied warranties that may not be waived or disclaimed as a matter of law) will Crosswater London be liable for any economic, special, incidental, indirect or consequential damages, whether based on breach of warranty, breach of contract, negligence, strict liability, or any other legal theory or otherwise. Without limitation to the foregoing sentence, damages that Crosswater London will not be responsible for include, but are not limited to: loss of profits, loss of savings or revenue; loss of use of the product or any associated equipment; cost of capital; cost of any substitute equipment, facilities, or services; downtime; the claims of third parties, including customers; loss of goodwill, loss of business opportunities and/or damages on account of personal injury, physical harm or injury to property.

To the maximum extent permitted by law, Crosswater London is providing this limited warranty in lieu of all other warranties, expressed or implied. To the maximum extent permitted by law, any implied warranty, including the implied warranties of merchantability or fitness for a particular purpose, are limited in duration to the duration of this warranty, or the applicable limitations period set by your state or province, whichever is shorter.

WARRANTY CLAIMS

Warranty claims may be made by calling (844) 992-8371 or by writing to:

c/o Crosswater London
Forte Brands
393 Fortune Boulevard
Milford, MA 01757
technical@fortebrands.com

Proof of purchase (original sales receipt) from the original purchaser must be made available to Crosswater London for all warranty claims. This Limited Warranty applies only to products that are installed in the United States of America and Canada.

©2023 Crosswater London.
All rights reserved.

The manufacturer reserves the right to make technical modifications without prior notice.

Crosswater London USA is a trade name of Bathroom Brands US, LLC, which is solely responsible for this warranty.

Forte Brands
393 Fortune Boulevard
Milford, MA 01757
T: 844-992-8371
F: 508-381-6068
E: info@fortebrands.com

crosswater 
LONDON