

crosswater^x

———— LONDON ————

Fenmore Floor-mount Tub Filler
28-05

Installation Instructions



For ease of installation you will need:

- To read the installation instructions completely before beginning.
- To read all warnings, care, and maintenance information.

Anti-scald protection is the responsibility of the installer and according to applicable codes

Before beginning installation, check for any damage that may have occurred during transport.

Note: Damage claims cannot be made during or after installation.

Installation Instructions

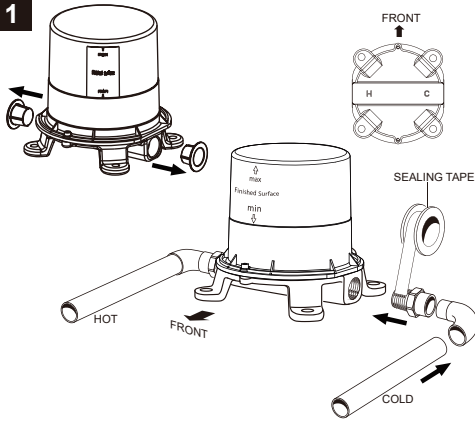

Sweat together Hot and Cold Supply assemblies. Apply sealing tape to threaded connections. With the maximum and minimum measurement in front, the hot supply is to be installed on the left inlet and the cold on the right as shown in the image above.

Note: The inlets are marked hot and cold on the bottom of the MANIFOLD MOUNTING BASE for reference.

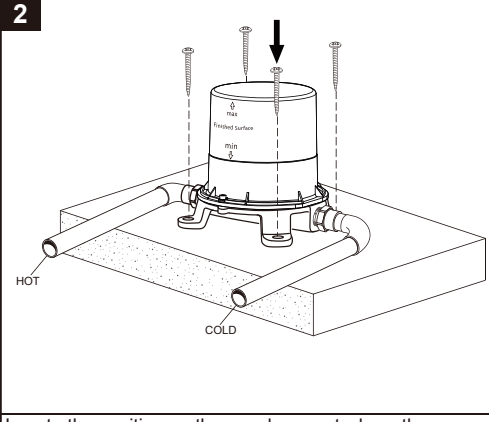

Locate the position on the wood support where the MANIFOLD MOUNTING BASE will be installed. Use the MANIFOLD MOUNTING BASE as a guide to mark the four mounting hole locations. Drill pilot holes if required. Secure the MANIFOLD MOUNTING BASE to the WOOD SUPPORT with SCREWS provided. Verify that the MANIFOLD MOUNTING BASE is level and then fully tighten SCREWS .

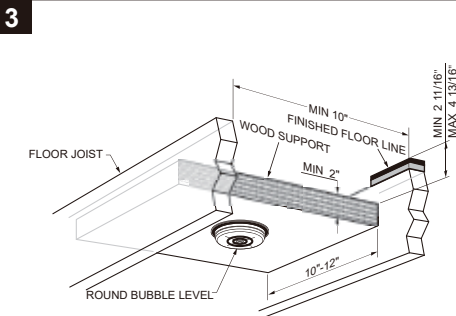

Adequate floor support is required. The WOOD SUPPORT must be a minimum of 2" (51mm) thick by 10" (254mm) wide. 2x6 lumber is NOT adequate for this application. WOOD SUPPORT must be located within the MIN. and MAX. arrows that are marked on the front of the PLASTER GUARD . IMPORTANT: Use a ROUND BUBBLE LEVEL to level the WOOD SUPPORT . The WOOD SUPPORT must be perfectly level. Secure WOOD SUPPORT to floor joists. Check for level again.

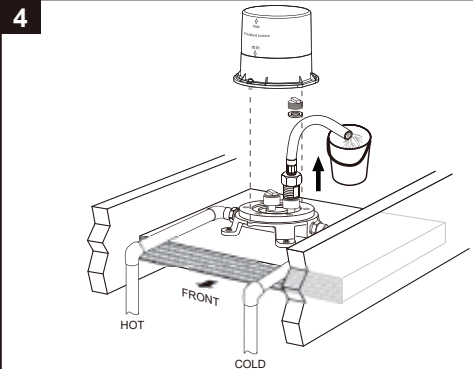

Finish all Hot and Cold supply connections to the MANIFOLD MOUNTING BASE .Loosen the two PLASTER GUARD SCREWS and remove the PLASTER GUARD. Make sure the two TEST PLUGS are tight, but do not over tighten.Turn on water supplies and test for leaks. Turn off water supplies. Replace PLASTER GUARD and attach with SCREWS.

5

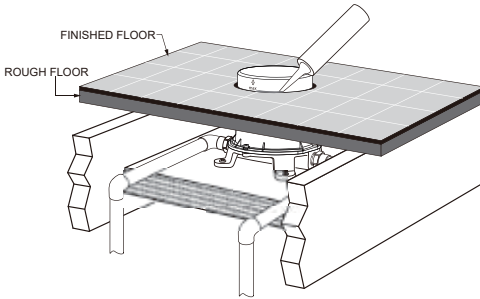

Complete the installation of the Finished Floor. Tile as close to the PLASTER GUARD as possible. Caulk between Finished Floor and PLASTER GUARD.

6

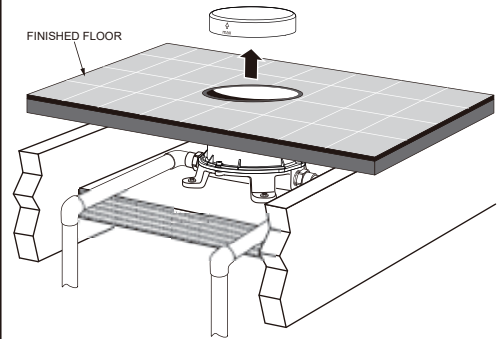

When you are ready to install the TUB FILLER cut the exposed part of the PLASTER GUARD flush with the finished floor. Be careful not to damage the floor.

7

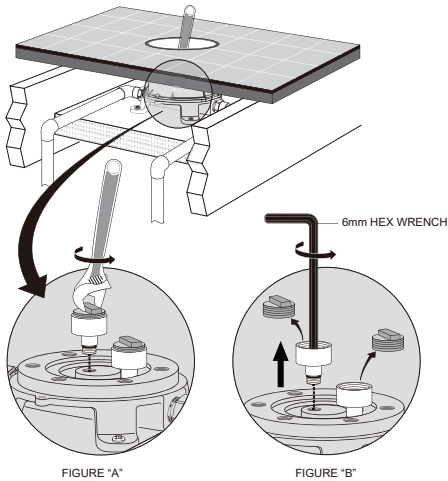

Turn off water supplies. With a wrench remove the center TEST PLUG as shown in Figure A. If the TEST PLUGS cannot be removed in one piece as shown in Figure A, the lower half will have to be removed using the supplied 6mm Hex Wrench as show in Figure B. Repeat step for the second TEST PLUG.

8

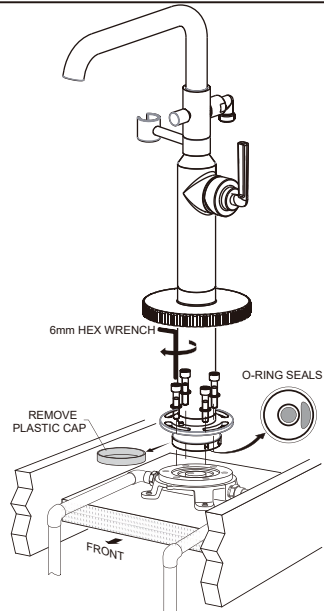

Remove PLASTIC CAP from bottom of the TUB FILLER. Before final installation, check that all sealing surfaces are clean and that the two O-RINGS are installed in the MOUNTING ADAPTER. Install the MOUNTING ADAPTER into the MANIFOLD MOUNTING BASE. Install the four MOUNTING SCREWS and WASHERS through the MOUNTING PLATE and into the MANIFOLD MOUNTING BASE. Do not tighten. Rotate the TUB FILLER right or left to align with Tub. Tighten MOUNTING SCREWS supplied with 6mm Hex Wrench to secure TUB FILLER.

9

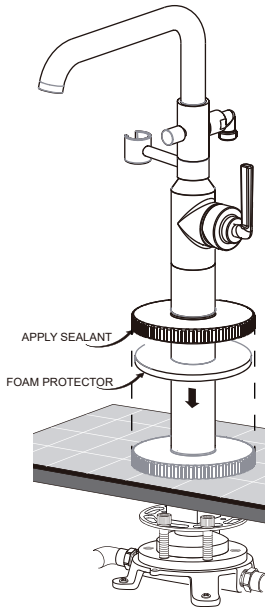

Turn on water supplies and check all connections for leaks. Check MANIFOLD connections for leaks. Remove foam protector and apply sealant to under side edge on ESCUTCHEON . Slide ESCUTCHEON down to finish floor. Press into place. Clean up excess sealant.

10

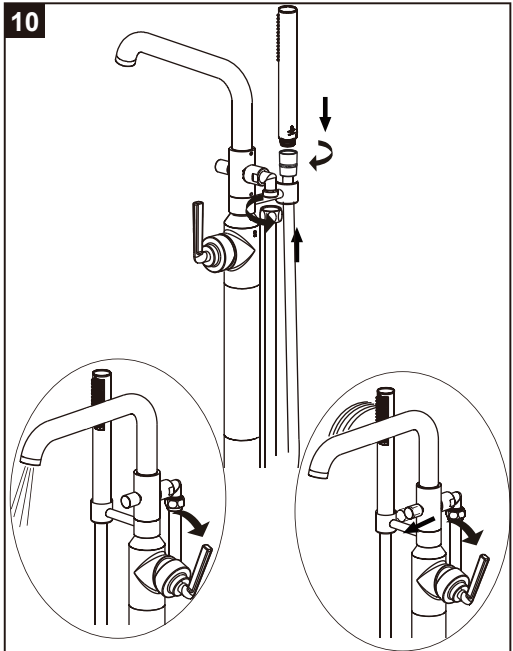

Attach hose to spout and handheld shower. Once hand shower is attached turn on TUB FILLER and test the diverter

11

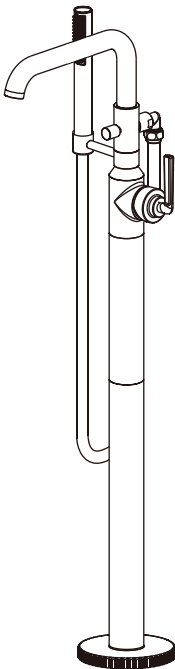

Installation is complete.

Cleaning Instructions

Rinse away any traces of soap and gently dry with a clean, soft cloth after each use. Rinse completely with water and dry any overspray. This will maintain the finish and avoid water spotting.

To remove mineral deposits, use a 50/50 solution of white vinegar and water. Do not allow the solution to soak on the product.

Simichrome Polish® contains a protective film to enhance maintenance and is helpful in preventing water spot buildup. Follow instructions to ensure optimum results.

Never use an abrasive material such as a brush or scouring pad to clean the surface. The use of abrasive cleaners, cleansers or disinfectants will alter the surface finish and void the warranty.

Do not allow certain materials such as toothpaste, cologne, shaving cream, nail polish remover, vinegar, wine, drain and glass cleaners to remain on the surface. Prolonged contact will alter surface finishes and void the warranty.

We DO NOT recommend using any household cleaners as many can cause damage to the finish.

Please see the website for care instructions for specific finishes.

Replacement Parts

NO.	Description	Part No.
1	Hand Shower	5Y0301802
2	Vaccum Breaker	5D8017100PL0
3	Aerator & Key	9Q1110PL
4	Diverter Knob	9Q245700
5	Hand Shower Hose	5G0000602
6	Finished Floor Flange and O Ring	5Y0342500
7	Complete Rough in with Mud Guard	9Q160301NT
8	Raw Floor Flange and Screws	9Q244500NT
9	6mm hex wrench	5T4000400ZZ0
10	Hot & Cold Supply	5G0M023701CC0
11	Finished Cartridge Dome	5L0P0024
12	Handle Plug & Screw	9Q1227
13	Handle	5Y0342600
14	Cartridge Nut	5T1C0084NT
15	Mixing Cartridge	9Q245900PL
16	Hand Shower Outlet	9Q247100
17	Check Valve	53001229PL
18	Diverter Cartridge	9Q245400

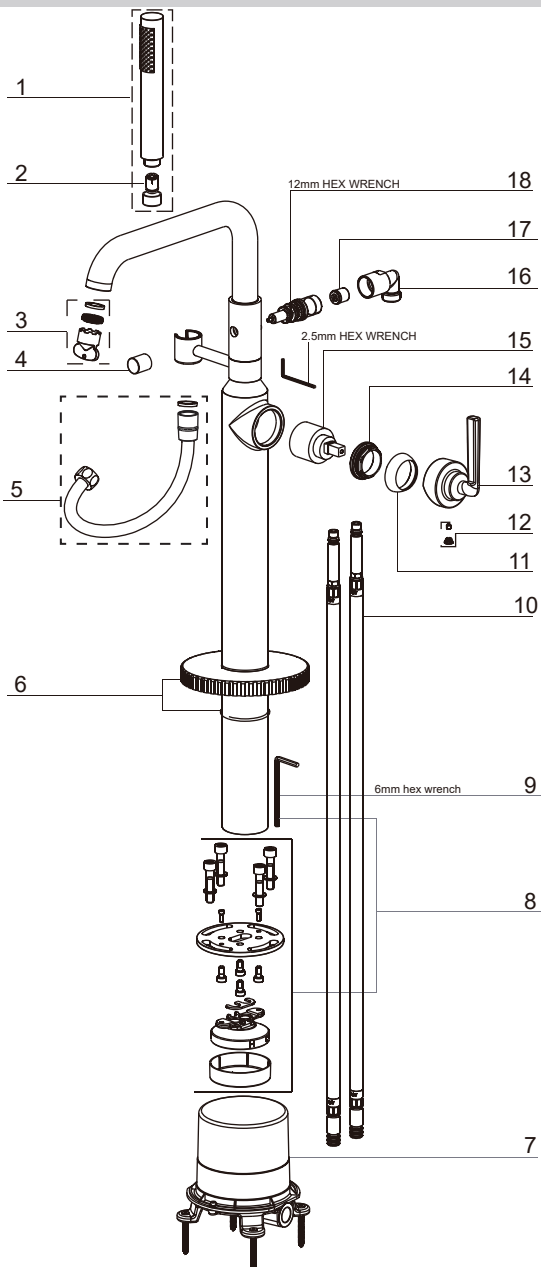

Applicable Standards/Codes

IAPMO certified to meet or exceed the following:

- ASME A112.18.1/CSA B125.1
- Uniform Plumbing Code
- National Plumbing Code of Canada



Installation Dimensions

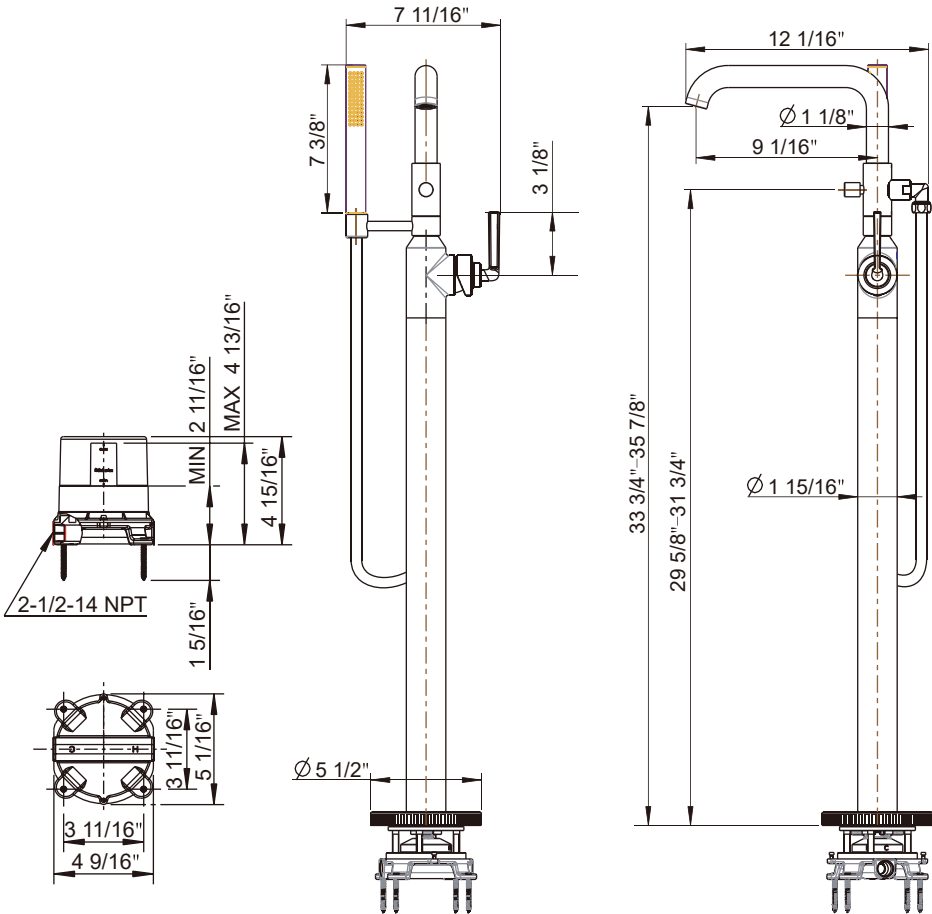

Warranty - This Crosswater London product is covered by a limited lifetime warranty. For full details, terms and conditions please visit our website.

For further information contact: **Crosswater London**, 393 Fortune Blvd., Milford, MA 01757

www.crosswaterlondon.com

Toll free number: 844-XWATER-1 (844-992-8371) tel: 508-381-6062 fax: 508-381-6068

email: technical@crosswaterlondon.com