

Heir Thermostatic Floor-mount Tub Filler

18-05

Installation Instructions

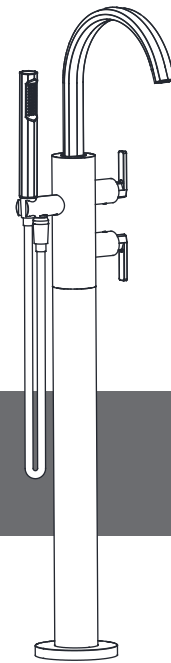

Introduction

This product has been fully inspected throughout the production process and only leaves our factory after a 15-step QC process. The faucets in this range are single flow (hot and cold water mix in the body) and should therefore be supplied with hot and cold water at balanced pressures. If the faucets are not supplied at balanced pressures then the mixer will not function correctly.

The minimum water pressure required for these faucets is 20 psi. The maximum water pressure is 60 psi beyond which pressure-reducing valves must be installed.

The faucets are fitted with half-turn ceramic disc cartridges which provide a good flow rate with very smooth movement.

IMPORTANT: Please read these instructions carefully before beginning and retain for future reference.

Before beginning installation, check for any damage that may have occurred during transport. **Note: Damage claims cannot be made during or after installation.**

Improper installation shall result in loss of warranty in case of damage caused by impacts or rubbing against rough surfaces.

We do not accept responsibility for any problems that may occur through incorrect installation.

Installation notes

The installation must comply with all plumbing codes including local codes and be installed by a licensed plumbing contractor.

IMPORTANT! Before installing a new faucet it is essential that the supply pipes are thoroughly flushed in order to remove any remaining debris, solder or other impurities. Failure to carry out this simple procedure can cause problems or damage to the working of the faucet.

Installing shut-off valves on incoming supply lines is recommended for ease of maintenance.

Turn off the main water supply before connecting to any existing pipework or doing any maintenance.

Please check for any hidden pipes and cables, electric or otherwise, before drilling holes in a wall or floor.

Dimensions

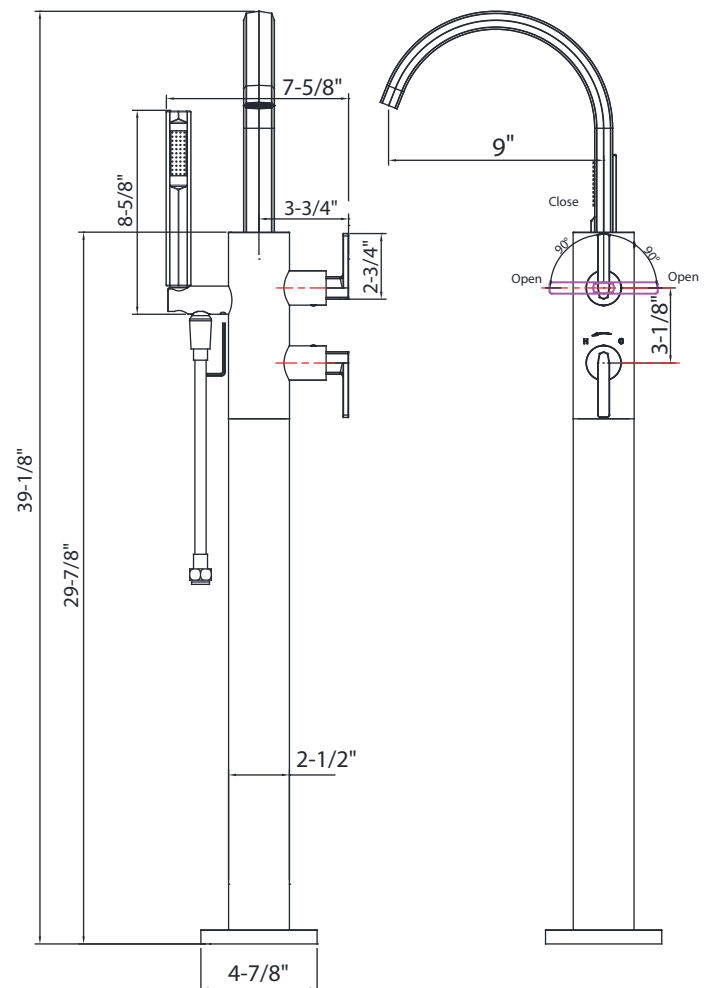

Tools required

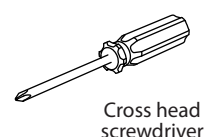
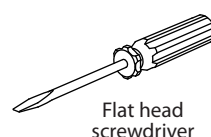
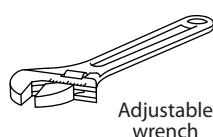
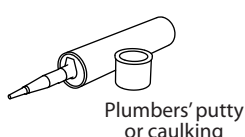
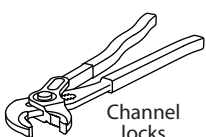

1 Installation

For rough valve body installation, see installation instructions for US-418ROUGH before following the trim installation detailed below.

With the main water supply turned off:

- Remove the 4 screws securing the plastic plate.
- Remove the plastic plate with the two plugs.
- Keep the 4 screws in a safe place for future use.
- Ensure that the 2 filter gaskets supplied in the rough separate accessory kit are fitted into the hot and cold feeds before the following installation.

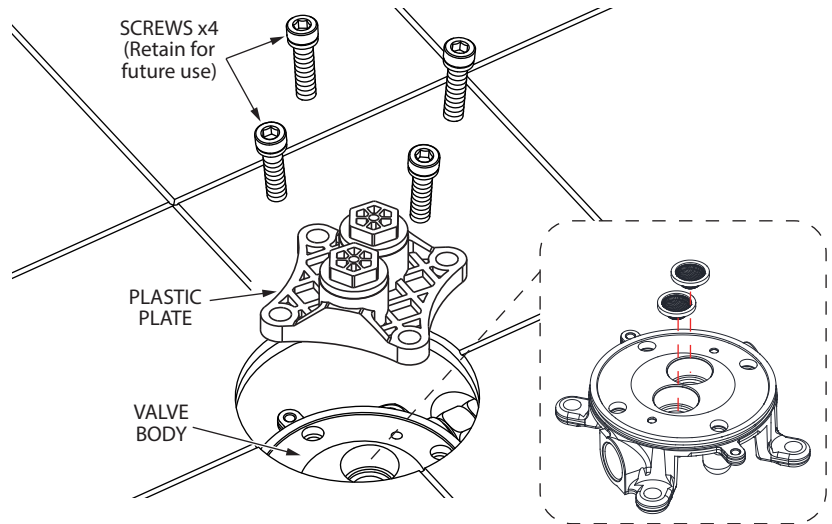

2 Installation

- Slide the cover plate up the upstand pipe, taking care not to mark the surface.
- Turn the body so that the spout is facing the correct direction.
- Push the faucet body down into the valve body.
- This is a pre-tested product so care should be taken not to put undue stress on the tails as this could damage the seals within the body of the faucet.
- Fix the faucet body onto the valve body using the 4 screws.
- At this point the water supply can be turned on and the unit tested for leaks.
- Extra care and time should be taken to check for leaks as the valve body will be concealed once installation is complete.
- Position the cover plate and use a suitable sealant to seal.

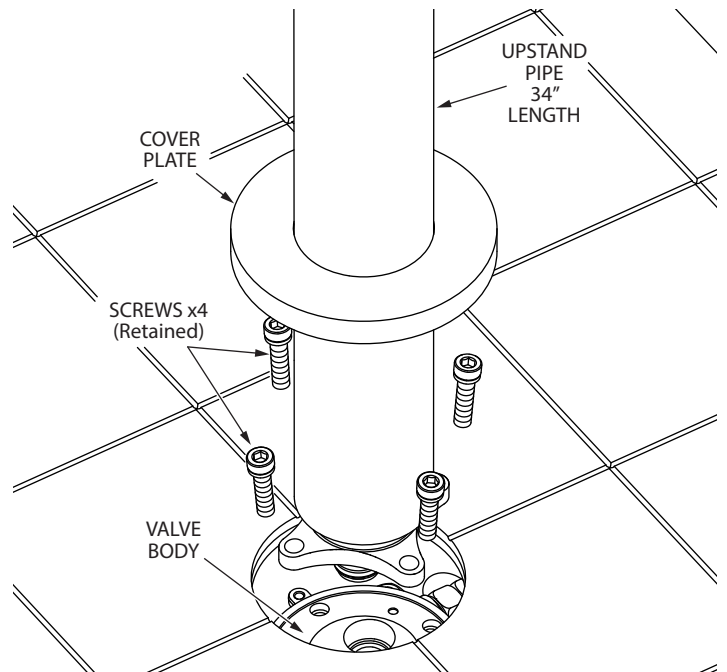

3 Installation

- Connect the hose cone to the handshower.
- Connect the hose nut to the faucet body.

Check all new connections for leaks.

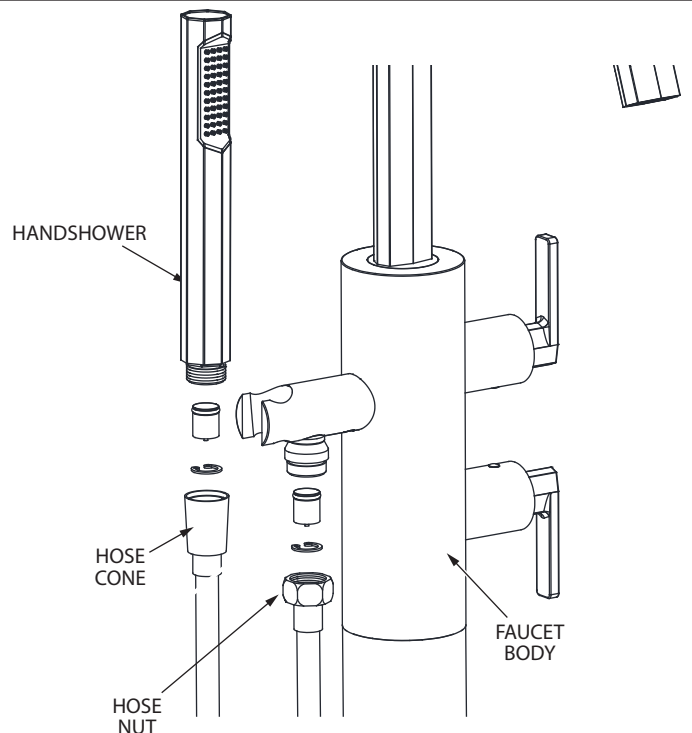

4 Maintenance

Cleaning the diverter cartridge

- The diverter cartridge should give trouble-free service however servicing is a straightforward process.

To remove the diverter cartridge

- With the water supply **turned off**, unscrew the pin on the handle taking care not to mark the finish.
- Using a hexagonal key loosen the set screw but do not remove.
- Remove the handle and gasket.
- Undo the retaining nut and pull the diverter cartridge out with the sleeve and brass sleeve attached.
- Wash the diverter cartridge with clean running water, dry and lightly grease the seal (only use silicone grease).
- Replace the diverter cartridge followed by the retaining nut, gasket and handle.

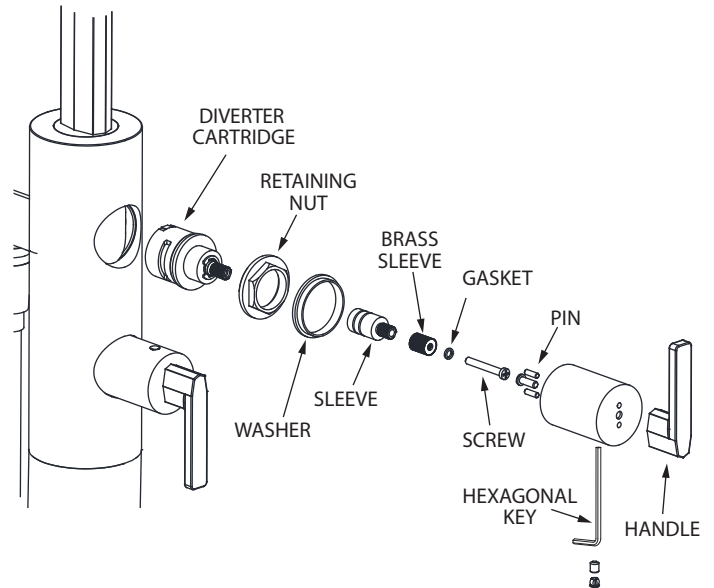

Thermostatic cartridge

- The thermostatic cartridge should give trouble-free service however servicing is a straightforward process.

To remove the thermostatic cartridge

- With the water supply turned off, unscrew the pin on the handle taking care not to mark the finish.
- Using a hexagonal key loosen the set screw but do not remove.
- Remove the handle and gasket.
- Remove the stop ring (take note of the orientation of the stop ring).
- Undo the retaining nut and pull the thermostatic cartridge out with the brass sleeve attached.
- Wash the thermostatic cartridge with clean running water and make sure that any trapped debris has been removed.
- Dry and lightly grease the seals (only use silicone grease) and replace the thermostatic cartridge.
- To re-assemble, reverse the sequence above taking care to replace the stop ring in the same orientation before removal.

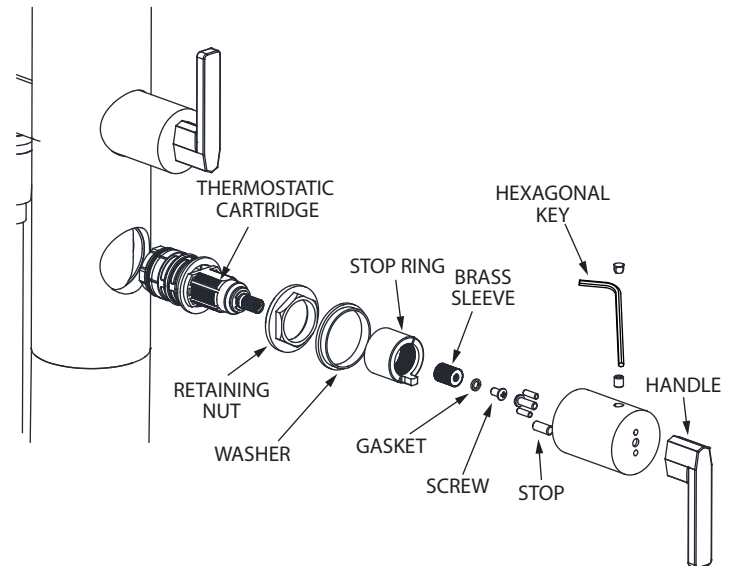

Thermostatic cartridge - set temperature to max 107.6° F

To set the thermostatic cartridge

- With the water supply **turned off**, unscrew the pin on the handle taking care not to mark the finish.
- Using a hexagonal key loosen the set screw but do not remove.
- Remove the handle and gasket.
- Remove the stop ring (take note of the orientation of the stop ring).
- Adjust the temperature of the thermostatic cartridge to max 107.6° F.
- To re-assemble, reverse the sequence above taking care to replace the stop ring in the same orientation before removal.

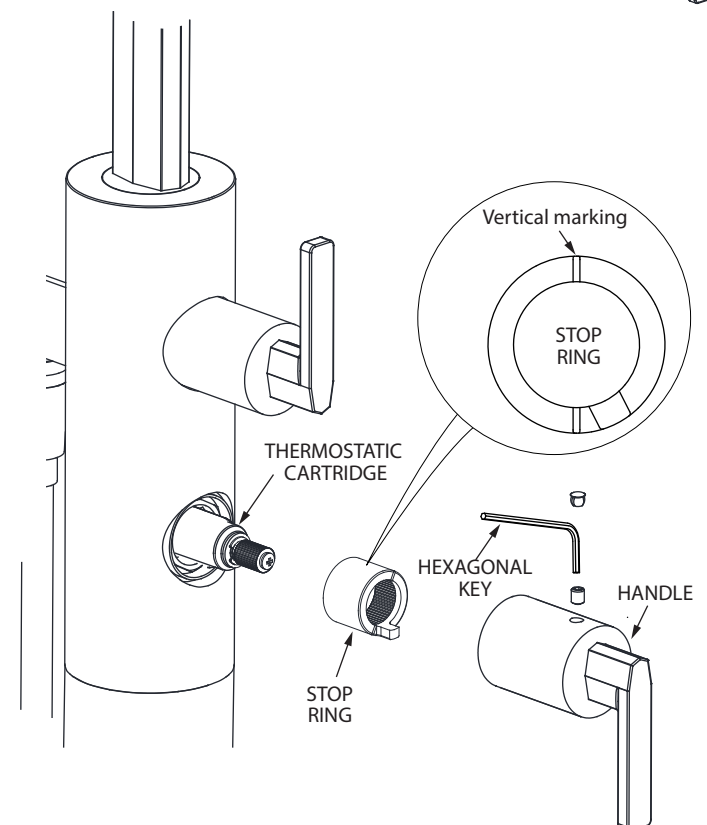

Flow rate

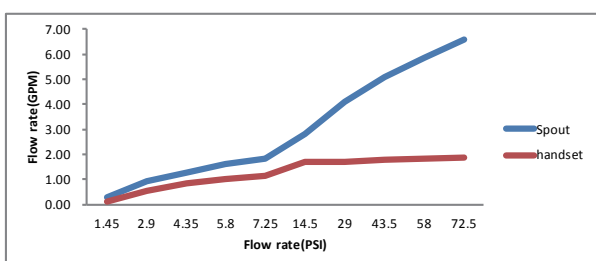

5 Cleaning Instructions

Rinse away any traces of soap and gently dry with a clean, soft cloth after each use. Rinse completely with water and dry any overspray. This will maintain the finish and avoid water spotting.

To remove mineral deposits, use a 50/50 solution of white vinegar and water. Do not allow the solution to soak on the product. Simichrome Polish® contains a protective film to enhance maintenance and is helpful in preventing water spot buildup. Follow instructions to ensure optimum results.

Never use an abrasive material such as a brush or scouring pad to clean the surface. The use of abrasive cleaners, cleansers or disinfectants will alter the surface finish and void the warranty.

Do not allow certain materials such as toothpaste, cologne, shaving cream, nail polish remover, vinegar, wine, drain and glass cleaners to remain on the surface. Prolonged contact will alter surface finishes and void the warranty.

We DO NOT recommend using any household cleaners as many can cause damage to the finish.

Please see the website for care instructions for specific finishes.