

US-PRO6005CW

US-PRO7005CW

# Installation Instructions

## PARTS SUPPLIED:

Check to make sure that all these parts are included in the package:

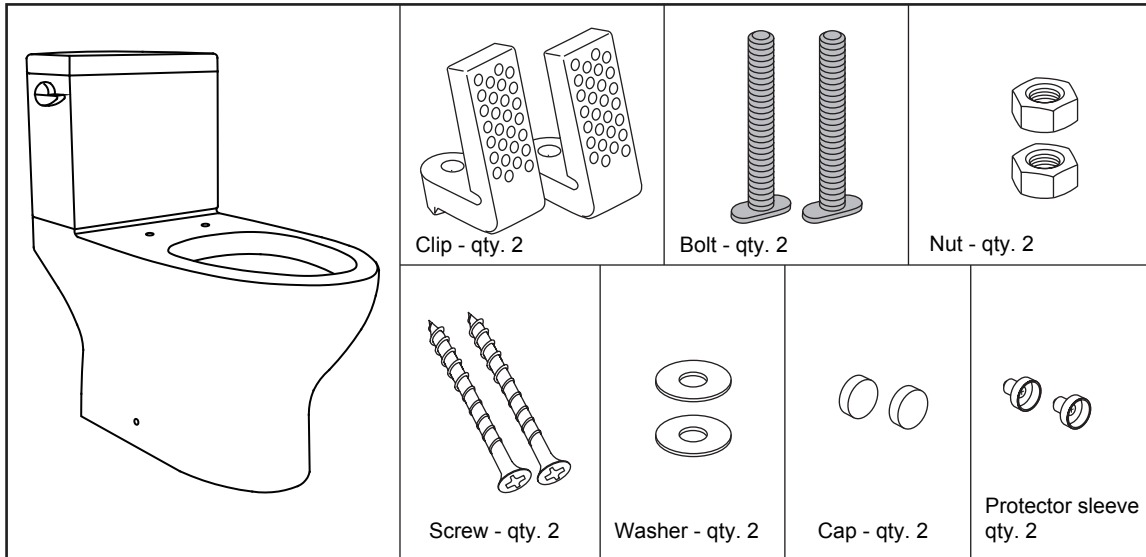

Mounting hardware product code: **US-BTF-HARDWARE**

## TOOLS REQUIRED:

- 12" pipe wrench
- 10" adjustable wrench
- Carpenter's level
- Tape measure
- Screwdriver
- Putty knife
- Drill
- Pliers
- For wood floor installation:
  - 11/64" drill bit for mounting block
- For concrete/tile installation:
  - 11/32" drill bit for mounting block

## MATERIALS REQUIRED:

(not included)

- Flexible supply tube/connector
- Supply stop valve
- Mounting T bolts & nuts (qty. 2)
- Wax ring/seal

## BEFORE INSTALLATION:

- Check for any damage that may have occurred during transport.
- **Note: Damage claims cannot be made during or after installation.**
- Read these instructions thoroughly before beginning work and retain for future reference
- Please leave instructions for the consumer. These instructions contain maintenance and warranty information.
- Remove the existing toilet. If new construction, purge the supply line.

In order to fit correctly, please check the following dimensions:

- 1) The distance between the finished wall and the center of the closet flange must be 12".
- 2) The water supply should be approximately 8" to 10" to the left (facing the bowl) from the center line of the closet flange, and approximately 6" above the finished floor.

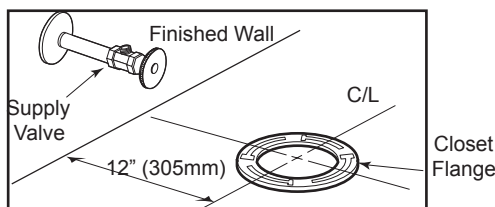
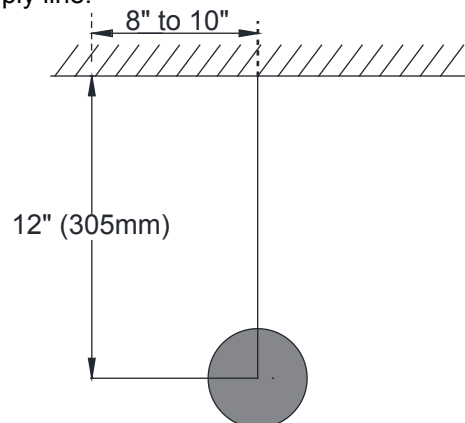

- 1) Clean any debris out of the closet flange (not supplied) then install the mounting bolts into the slot of the flange head down with the threaded shank of the bolt pointed upward as shown (see Figure 1).  
Slide each bolt until the end of slot.

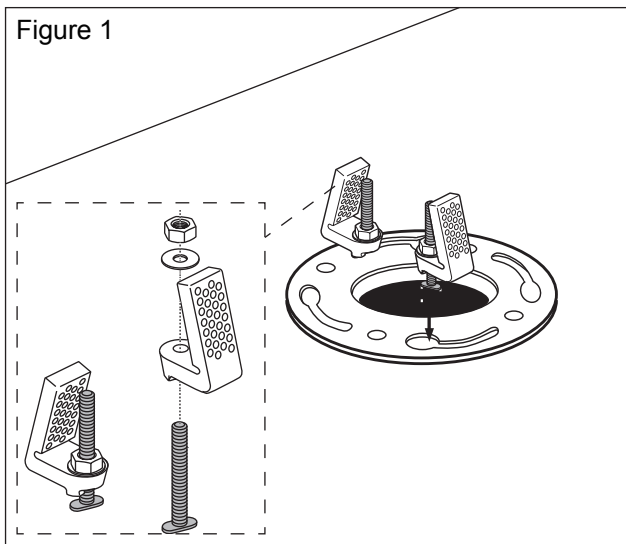

- 2) Firmly press a new wax seal (not supplied) onto the circular recess around the outlet opening (see Figure 2).

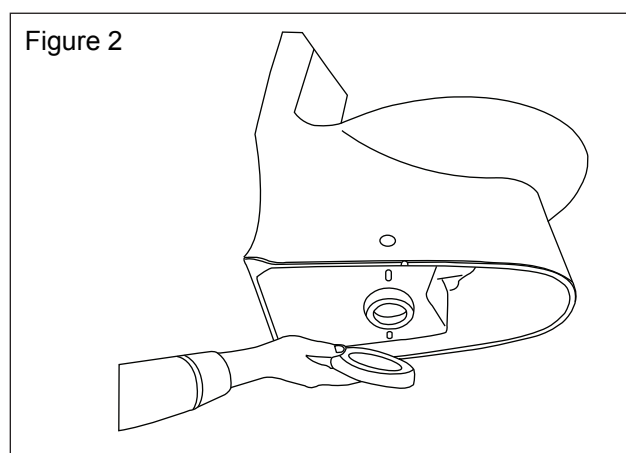

- 3) Place the toilet bowl over the socket and mounting blocks (see Figure 3).

**CAUTION:**

- To prevent water and odor leakage, please ensure that the wax seal is fitted properly between the socket and the flange. Do not overtighten the nuts as damage to the plastic parts may result.

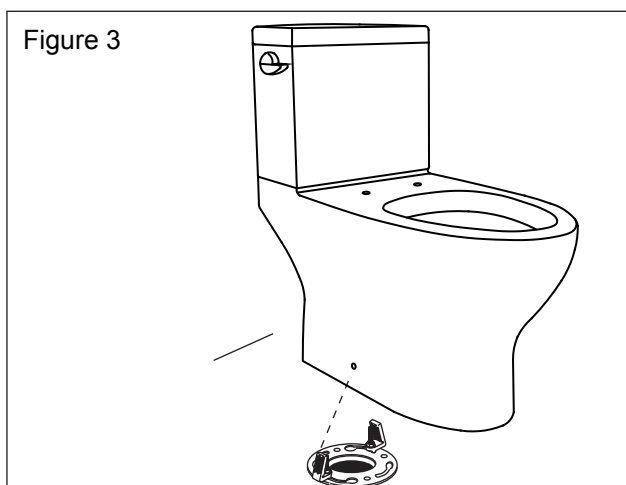

- 4) Fit protector sleeves and install side screws. Cover the screw head with the provided screw cap (see Figure 4).

**CAUTION:**

- In order to prevent leakage, be sure to insert the toilet all the way into position.

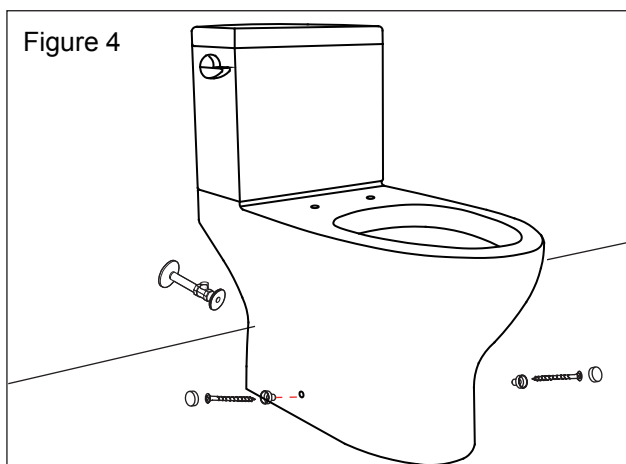

# Fill & Flush Valve Installation Instructions

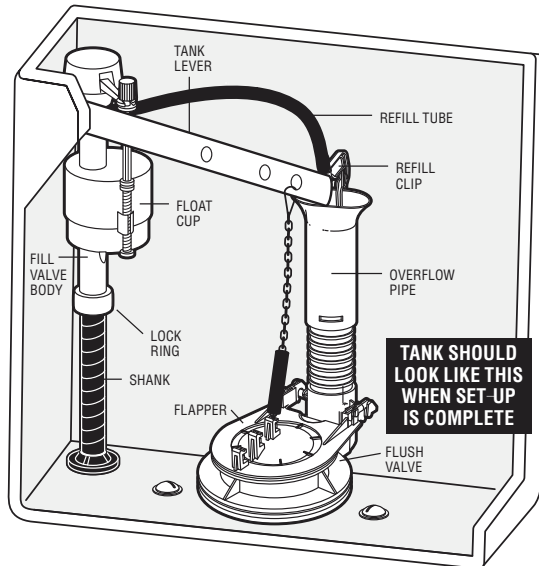

## Flush Valve Installation Instructions

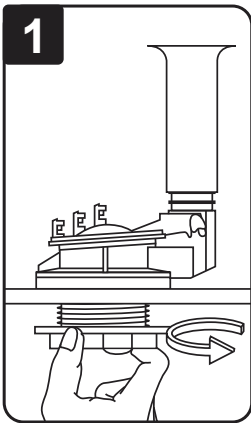

**1** Before installing the flush valve in the tank, remove the tank-to-bowl gasket and nut from the bottom of the threads of the new flush valve. Position the overflow pipe toward the back of the tank but not over the bolt holes. Thread large nut onto the threads. Hand tighten only. **DO NOT OVERTIGHTEN** or tank may crack.

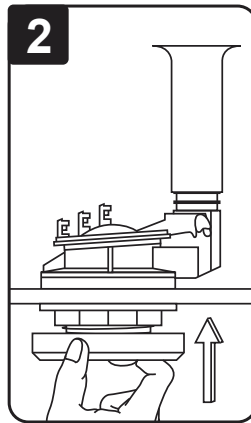

**2** Slide new tank-to-bowl gasket over the nut with the narrow side facing down. Gasket should cover the nut completely.

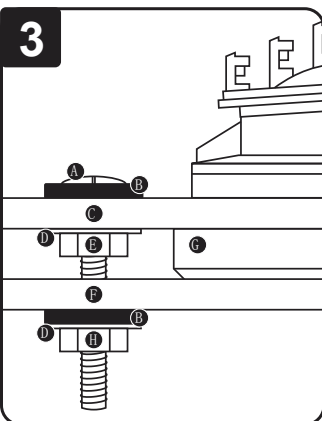

**3** Correct order of bolts, washers and nuts:

- A) Bolt head
- B) Rubber washer
- C) Toilet tank
- D) Metal washer\*
- E) Metal hex nut\*
- F) Toilet bowl
- G) Tank-to-bowl gasket
- H) Plastic nut

NOTE: Place metal washers and hex nuts onto brass bolts before installing the tank on the bowl.

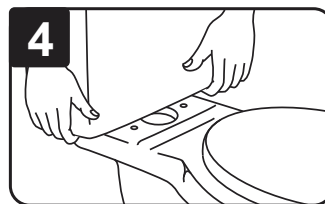

**4** Optional: Before replacing the tank on the bowl, place a metal washer and hex nut onto the bolt under the tank and hand tighten until snug. Then place the tank back on the bowl so that the tank-to-bowl gasket fits evenly. Level the tank. Under the bowl, attach a rubber washer, a metal washer and a nut. Tighten the nuts under the bowl evenly until the tank is stable and doesn't rock. **DO NOT OVERTIGHTEN** or the tank or bowl could break.

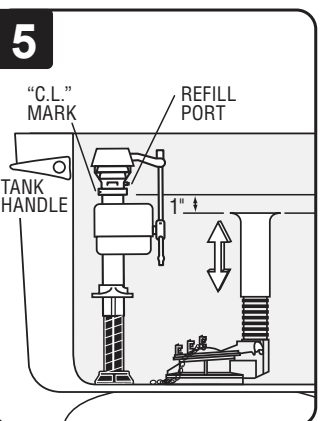
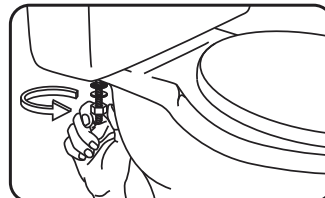

**5** When installed, the top of the overflow pipe of the flush valve must be at least 1" below the C.L. mark of the fill valve.

NOTE: Top of the overflow pipe should be below the handle/lever hole of the toilet tank and above the water level of the tank when filled.

To adjust the height of the overflow pipe, pull up or push down.



**6** The refill tube must be attached to the top of the overflow pipe. Push refill tube onto the nipple at the top of overflow pipe. Then attach the other end of refill tube to the nipple of the fill valve. You may need to trim the rubber hose.

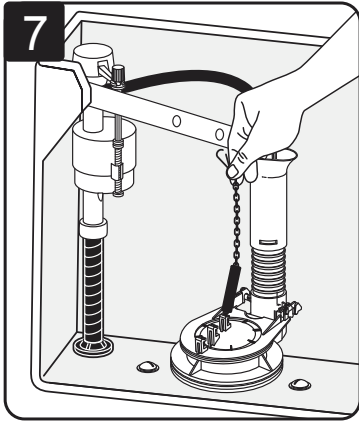

7 Connect the flapper chain to the tank lever. Allow for 1/2" of slack in the chain when the flapper is closed.

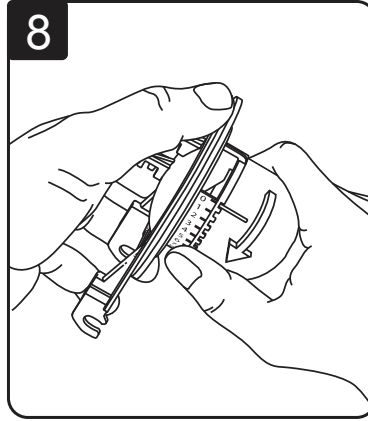

8 Remove the flapper from the flush valve by pulling up the frame of flapper one side at a time.

The flapper is adjustable from 0 to 10. 0 is a quick flush, 10 is a long flush, allowing you to adjust the flush performance to match the toilet's original setting. The tab on the white plastic dome can be set to any of the numbered notches. Pull on the dome slightly and turn until the tab is in the desired setting.

## TROUBLESHOOTING

### MY FLAPPER CLOSES QUICKLY & I DON'T GET A COMPLETE FLUSH

- Check the flapper chain. If it looks loose, tighten it; if it looks straight, loosen it a bit and try to flush again. Chain should have 1/2" of slack.
- Adjust the flapper setting to a higher number (See "Installation" step 8).

### MY FLAPPER STAYS OPEN TOO LONG & I GET A DOUBLE-FLUSH

- Adjust the flapper setting to a lower number (See "Installation" step 8).

#### \*NOTES:

- Installation Instruction #3: This Is Optional

- D) Metal Washer\*
- E) Metal Hex Nut\*

Not all toilets will fit together when metal washer and metal hex nut are used

## Fill Valve Installation Instructions

### 1 Preparing the Fill Valve for Installation

#### Fill Valve Assembly Parts

- A) Refill tube
- B) Shank washer
- C) Locknut
- D) Threaded shank

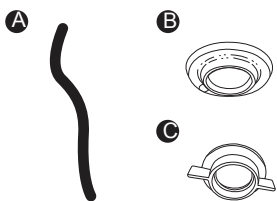

Place shank washer onto threaded shank of fill valve flat side up.

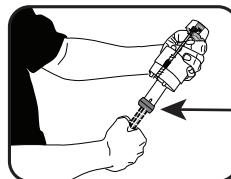
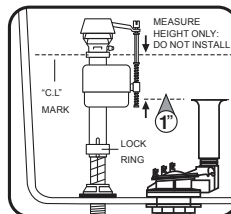
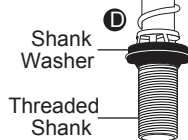

Position fill valve in tank, but do not fully install yet. Top of fill valve **MUST** be set 3" above overflow pipe. This will automatically place **CRITICAL LEVEL MARK / C.L. Mark**, 1" above the top of overflow pipe. Remove fill valve from tank to adjust height.

Adjust the height of the fill valve by holding the lower shank with the right hand and the top of the valve with the left hand. Twist the lower shank counter clockwise to increase valve height and clockwise to decrease valve height. You should hear several "clicks". Place valve in tank and check height again. **THE CRITICAL LEVEL MARK**, identified by C.L. on valve, **MUST** be positioned 1" above top of overflow pipe. This is a requirement of the **Universal Plumbing Code**.

**Do not move lock ring.** It holds the valve body and shank together under pressure. Do not interchange body with old shank as leaking can occur.

### 2 Installing New Fill Valve

Place the fill valve in the tank. Make sure that the lid will sit on top of the tank without touching the valve. Align the fill valve nipple to face the center of the tank.

Press down on the shank from inside the tank while tightening the lock nut.

Hand-tighten only. **DO NOT OVERTIGHTEN.** Overtightening may crack the fill valve or tank causing flooding. Make sure the float cup does not touch the tank walls or tank lever and flush valve.

Attach one end of the refill tube to the top of the overflow pipe. Attach the other end of the tube to the nipple on the fill valve ( see image to the right). Cut the tube as necessary.

**WARNING:** Do not shove the refill tube down overflow pipe. This may cause significant water waste.

Correct set up of refill tube



### 3 Adjusting Tank Water Level

With the water turned on, set the float cup to the desired level by turning the water level adjustment screw. Make the adjustment while the tank is filling.

To adjust the tank water, turn the adjustment screw clockwise to raise the water level, or counter clockwise to lower the water level. Repeat if necessary.

**HINT:** When the adjustment screw is twisted 8 times, the float moves 1/2".

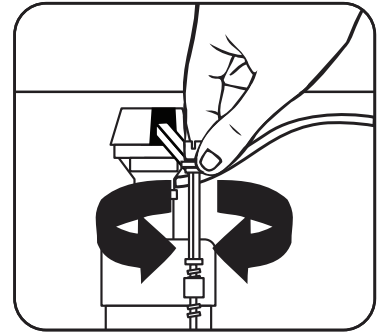

### 4 Code Compliance

Once the fill valve is installed, ensure that the overflow pipe and water level of the tank are correctly set.

1. THE TOP OF OVERFLOW PIPE (A) must be a minimum of 1" below the TANK LEVER HOLE (B)
2. WATER LEVEL (C) is set below the top of the overflow pipe (Fluidmaster recommends 1/2").
3. THE CRITICAL LEVEL MARK / C.L. Mark (D) identified by C.L. on the fill valve must be positioned 1" above the top of the overflow pipe. This is a requirement of the Universal Plumbing Code.

Code Compliance helps protect your home & drinking water supply.

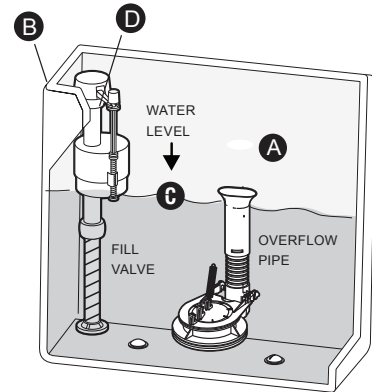

### 5 Attach Water Supply Connector

Inspect water supply connector. Replace if it is worn or over 5 years old to prevent flooding and property damage.

A. Attach the water supply coupling nut to the fill valve. Turn the coupling nut clockwise by hand until tight.

**WARNING:** Do not overtighten the nut as it could damage the fill valve or coupling nut, resulting in flooding and property damage. Fluidmaster Click Seal® connector is recommended: A perfect seal every time without overtightening.

B. Turn on the water supply and check for leaks. If you find leaking at bottom of the tank, turn the nut just enough to stop the leaking. Then flush the toilet to ensure leaking has ceased.

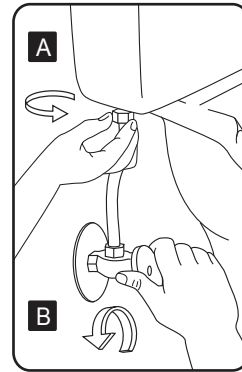

## TROUBLESHOOTING

#### IF FILL VALVE DOES NOT TURN ON, WILL NOT TURN OFF, OR WILL NOT REFILL THE TANK AFTER THE FLUSH

- Remove the top cap and check for debris. If you find debris, or flow is weak: Inspect the lower section of the fill valve for partial blockage. Partial blockage may be at the shut off valve or in the water supply line (See "REMOVING THE VALVE CAP ASSEMBLY & FLUSHING OUT DEBRIS").
- If the fill valve has been in use for some time and/or float cup does not drop when flushing the tank, replace seal with a genuine Fluidmaster 242 seal (See "IF REPLACING SEAL").

#### IF FILL VALVE TURNS ON AND OFF BY ITSELF

- This indicates the tank is losing water. The fill valve is refilling lost water. Clean the flapper and drain seat. If the leak continues, change the flapper or flush valve. Install Fluidmaster 540A.

#### IF WATER LEVEL IN BOWL IS TOO LOW

- Make sure the refill tube is supplying water down the overflow pipe.
- Water level in the tank may be too low. Raise the water level to 1/2" below the top of the overflow pipe (See "ADJUSTING TANK WATER LEVEL"). You may have to lengthen the fill valve in order to increase the water level in the tank (See "PREPARING THE FILL VALVE FOR INSTALLATION").
- The flapper may be closing too soon. Give the flapper chain approximately 1/2" of slack.

### Removing Valve Cap Assembly, Flushing Out Debris, Replacing Seal, & Replacing Valve Cap Assembly

#### Removing Valve Cap Assembly

Turn off the water supply & flush out the tank. Push the float up with right hand (see picture). Grip and hold the shaft under the float with right hand. With left hand, twist the cap and lever counter clockwise 1/8th of a turn to unlock the top cap. Pressing down on the top may be helpful with older valves. Let the cap assembly hang on float cup.

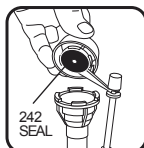

#### Flushing Out Debris

Hold the cup upside down over uncapped valve to prevent splashing. Turn the water supply on and off a few times. Turn the water supply off when putting the cap back on the valve.



#### Replacing Seal

If replacing the seal, use only a genuine Fluidmaster 242 seal.



#### Replacing Valve Cap

- Place cap assembly on top of gray valve body by aligning cap arm and adjustment rod next to refill tube.
- Press down on top cap while rotating top & arm clockwise to locked position.

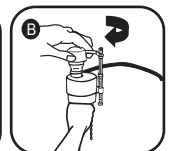
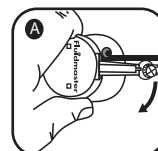

If replacement mounting hardware is needed, please send an email to [technical@fortebrands.com](mailto:technical@fortebrands.com) and ask for **US-BTF-HARDWARE**.

**IMPORTANT:** Please keep a copy of these instructions on the property in which the product was installed.

# Trip Lever Installation Instructions

## TOOLS NEEDED:



1. Remove the tank lid. Disconnect the flapper chain/linkage from the lever. Unthread the nut from the old lever. Remove the lever from the tank.
2. For standard front-mount tanks go to step 3. For a SIDE OR ANGLE-MOUNT TANK, slowly bend the new lever arm to match the shape of the old lever arm. DO NOT BEND THE ARM QUICKLY OR BACK AND FORTH REPEATEDLY.
3. Measure the length of the existing lever arm. If necessary, trim the new arm at the cut line that best matches the length of the old arm (a hacksaw is recommended for best results).
4. Slide the arm through the tank hole until the handle shank fits snugly. Slip the lock nut over the lever (flat side facing handle). Start the nut on the threads (reverse thread). DO NOT TIGHTEN FULLY.
5. Connect the flapper chain/linkage to the arm hole that provides the best lift. The chain should have a slight slack when the flapper is in the closed position. Check the lift action for proper flush. Tighten the lock nut. DO NOT OVERTIGHTEN. Overtightening may crack the tank and void the warranty.

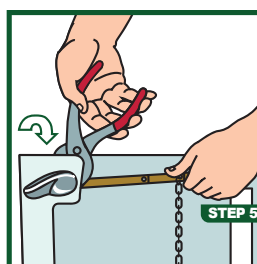
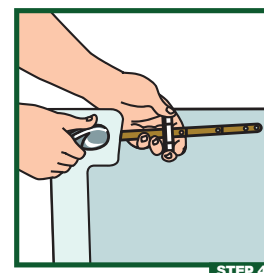
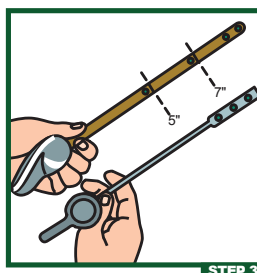
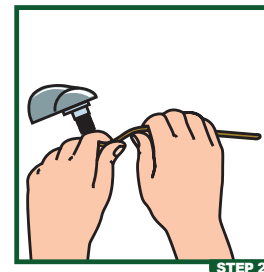
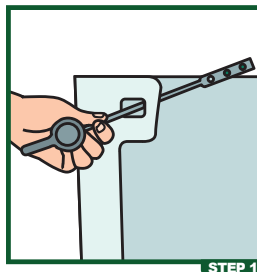

## After Installation/Adjustment

Flush the toilet two to three times to confirm that there is no water leakage and that the push mechanism is working properly.

- 6) Connect the opposite end of the water supply hose to the angle stop (see Figure 5). It is recommended to use a flexible supply hose. Hand tighten only - do not use plumber's putty or other sealants. Open the supply valve and flush the toilet several times. Check all the connections for leaks and periodically afterwards following the installation.

Minimum supply pressure is 2.6psi.

## CLEANING INSTRUCTIONS

A mild detergent, warm water and a soft cloth will remove normal dirt and soap accumulations from surfaces. Soft abrasive cleaners may be used on vitreous china. Never use abrasive cleaners without water. Do not use caustic cleaners or disinfectants as they can alter the surface finish and void the warranty.

Use toilet bowl cleaners on the inside of the bowl only. Remove any splashes of cleaner solution from plastic or plated surfaces immediately.

Do not use in-tank cleaners as they can seriously damage the fittings in the tank. This damage could cause leakage and result in property damage.

**Crosswater London** shall not be responsible or liable for any damage that occurs as a result of the use of in-tank cleaners.

Do not allow certain materials such as toothpaste, cologne, shaving cream, nail polish remover, vinegar, wine, drain and glass cleaners to remain on the surface. Prolonged contact can alter surface finishes and void the warranty.

Figure 5

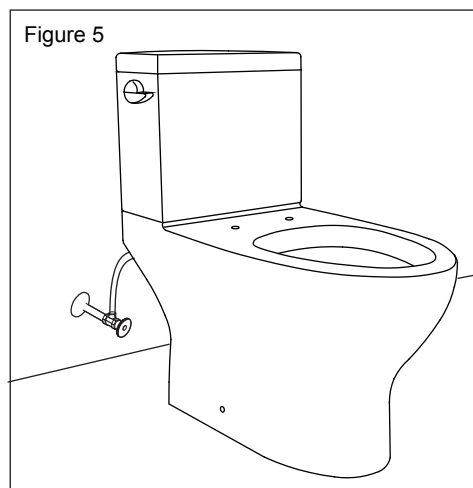

**Warranty - Chinaware** - Limited lifetime. Commercial: 1 year. **Mechanical parts:** 5 years, Commercial: 1 year.

For further information contact: **Crosswater London**, 393 Fortune Blvd., Milford, MA 01757  
Toll free number: 844-XWATER-1 (844-992-8371) tel: 508-381-0433 fax: 508-381-6068

[www.crosswaterlondon.com](http://www.crosswaterlondon.com)  
email: [technical@crosswaterlondon.com](mailto:technical@crosswaterlondon.com)

Issue date: 21042020