

US-HEI9005CW-SF

Installation Instructions

PARTS SUPPLIED:

Check to make sure that all these parts are included in the package:

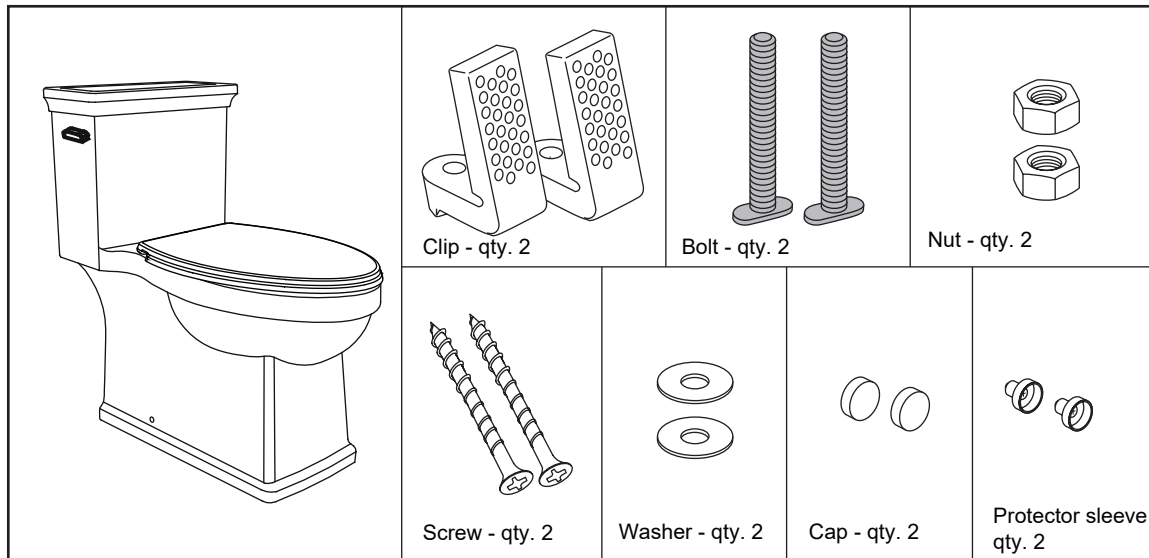

TOOLS REQUIRED:

- 12" pipe wrench
- 10" adjustable wrench
- Carpenter's level
- Tape measure
- Screwdriver
- Putty knife
- Drill
- Pliers
- For wood floor installation:
 - 11/64" drill bit for mounting block
- For concrete/tile installation:
 - 11/32" drill bit for mounting block

MATERIALS REQUIRED:

(Not Included)

- Flexible supply tube/connector
- Supply stop valve
- Mounting (T) bolts & nuts (2pc)
- Wax ring/seal

BEFORE INSTALLATION:

- Check for any damage that may have occurred during transport. **Note: Damage claims cannot be made during or after installation.**
- Read these instructions thoroughly before beginning work and retain for future reference.
- Please leave instructions for customer. These instructions contain maintenance and warranty information.
- Remove the existing toilet. If new construction, purge the supply line.

In order to fit correctly, please check the following dimensions:

- 1) The distance between the finished wall and the center of the closet flange must be 12". Water supply should be approximately 8" to 10" to the left
- 2) The water supply should be approximately 8" to 10" to the left (facing the bowl) from the center line of the closet flange, and approximately 6" above the finished floor.

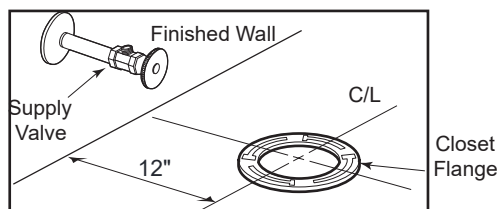
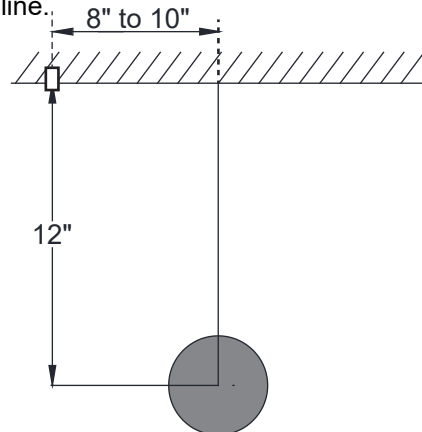

- 1) Clean any debris out of the closet flange (not supplied), then install the mounting bolts into the slot of the flange head down with the threaded shank of the bolt pointed upward as shown (See figure 1).
Slide each bolt until the end of slot.

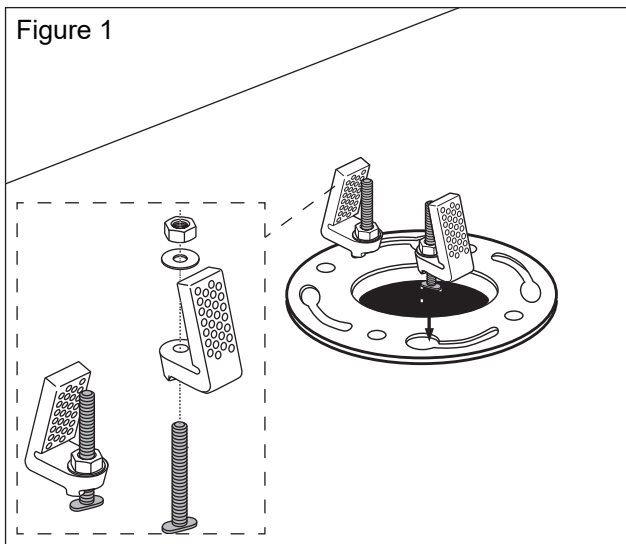

- 2) Firmly press a new wax seal onto the circular recess around the outlet opening (See figure 2).

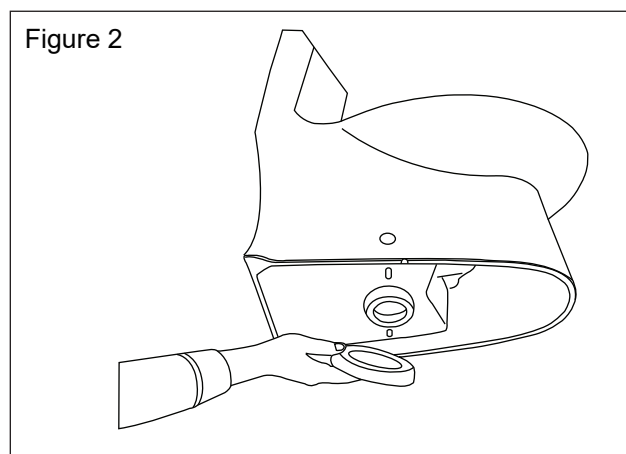

- 3) Place the toilet bowl over the socket and mounting blocks (See figure 3).

CAUTION:

- To prevent water and odor leakage, please ensure that the wax seal is fitted properly between the socket and the flange. Do not overtighten the nuts, as damage to the plastic parts may result.

- 4) Fit protector sleeves and install side screws. Cover the screw head with the provided screw cap (see Figure 4).

CAUTION:

- In order to prevent leakage, be sure to insert the toilet all the way into position.

- 5) Carefully place the lid on top of the tank.

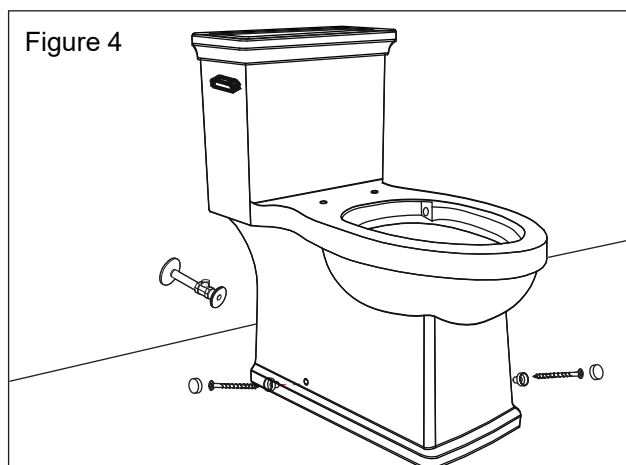
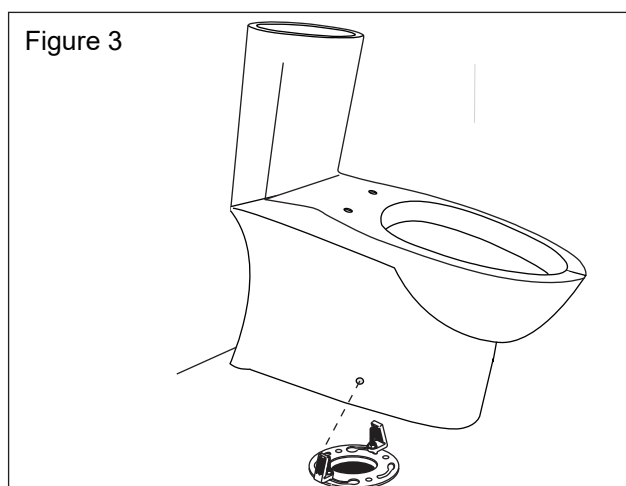

After Installation/Adjustment

Flush the toilet two to three times to confirm there is no water leakage and that the lever mechanism is working properly.

- 6) Connect the opposite end of the water supply hose to the angle stop (see Figure 5). A flexible supply hose is recommended. Hand tighten only - do not use plumber's putty or other sealants. Open the supply valve and flush the toilet several times. Check all the connections for leaks and periodically afterwards following the installation.

Figure 5

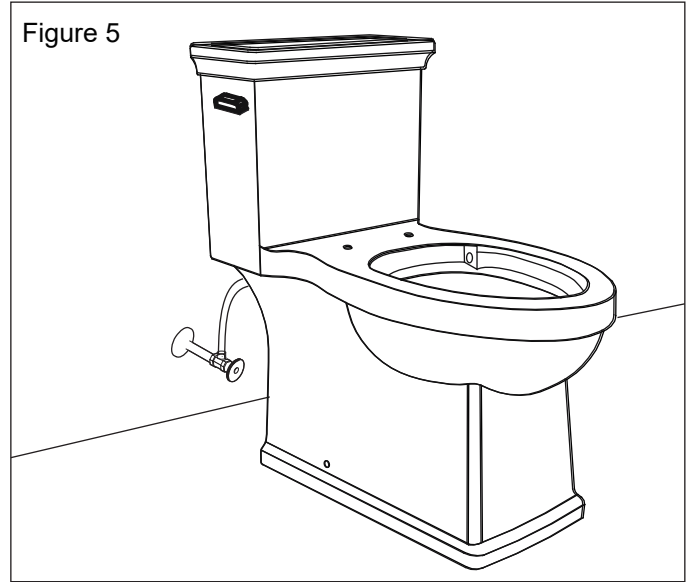

Fill Valve Installation Instruction

Replacement Installation

- 1) Shut off the water supply. Flush the toilet and remove any remaining water from the tank. Remove the old fill valve.
- 2) Install new fill valve by sliding the threaded portion of the shaft through the hole in the bottom of tank.
- 3) Thread mounting nut onto exposed shaft under the tank/bowl and tighten nut.
WARNING! Do not overtighten.
- 4) Connect the water supply.

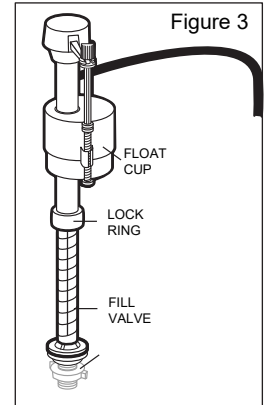
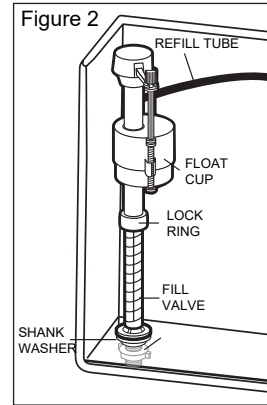
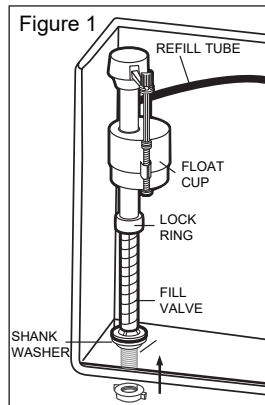

Water Level Adjustment

- 1) Loosen the lock ring (see Figure 3)
Pull up the valve and set it to the desired water level, then turn it clockwise until the valve snaps into the locked position.
- 2) Turn on the water supply.

Flush Valve Installation Instruction

Replacement Installation

- 1) Turn off water supply and flush the toilet.
- 2) Remove the tank lid and place it upside down on a clean surface.
- 3) Note the orientation of the flush valve for reassembly.
- 4) Remove the flapper from flush valve by pulling up frame of flapper one side at a time.
- 5) With a screwdriver, loosen the two screws and metal plates holding the valve. Then remove the flush valve from the tank.
- 6) Install a new flush valve into the tank.
Flush the toilet several times using side lever to check for proper operation. Check for any leak.

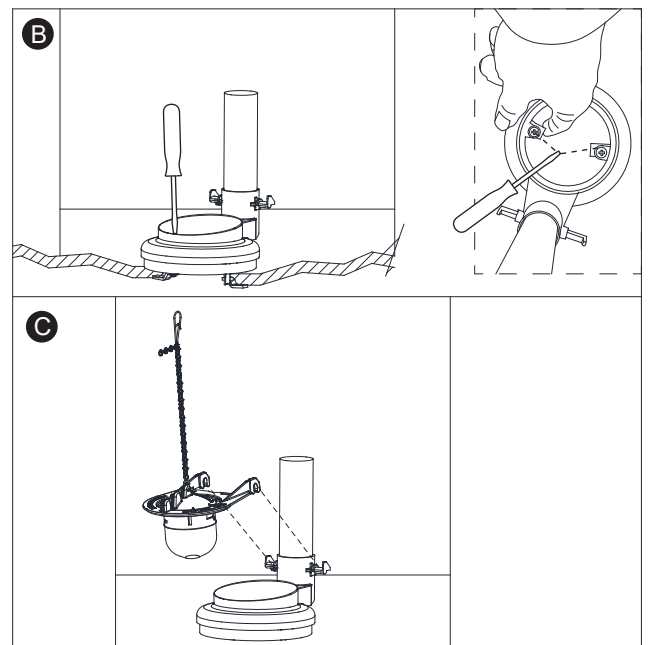
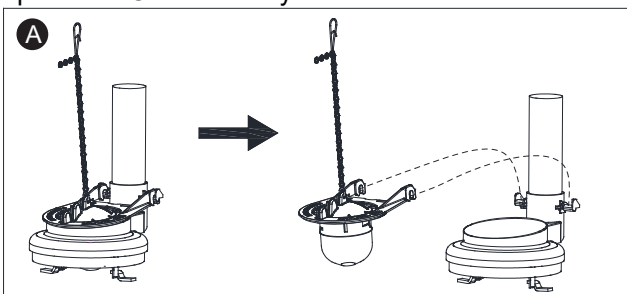

Refill Clip Install

The refill tube must be attached to the top of the overflow pipe. Push the refill tube onto the nipple at the top of overflow pipe. Then attach the other end of the refill tube to the nipple of the fill valve. The rubber hose may need to be trimmed.

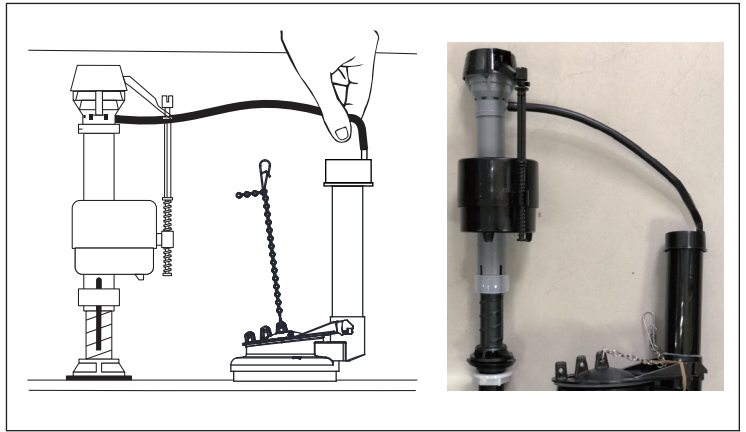

Connect the flapper chain to the tank lever. Allow for 1/2" of slack in the chain when flapper is closed.

Reconnect water supply line to the bottom of the fill valve. Hand tighten the plastic nut of supply line to the fill valve shank. **DO NOT OVERTIGHTEN.**

- (1). Turn on the water supply and check for any leaking.
- (2). If no leaks appear, perform test flush.
If leak appears tighten nut just enough to stop leak.

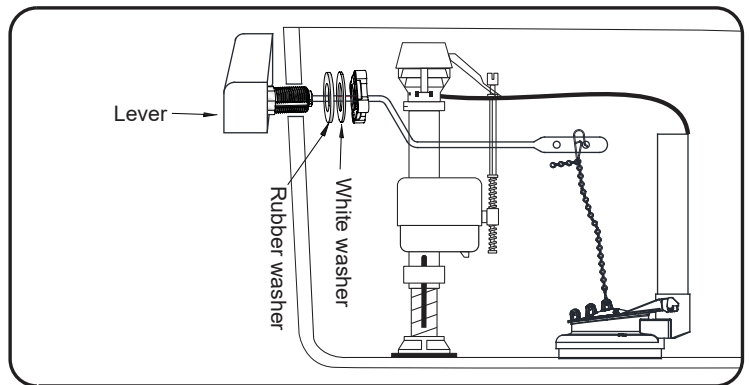

Troubleshooting guide

Problem	Possible cause	Corrective action
Does not flush.	<ol style="list-style-type: none"> a. Water supply valve closed. b. Supply line blocked. c. Flush valve chain too loose or disconnected. d. Sand or debris lodged in water control. 	<ol style="list-style-type: none"> a. Open valve and allow water to fill tank. b. Shut off water supply, disconnect supply line, and inspect all gaskets and washers. Reassemble. c. Re-adjust chain length as required. d. Shut off water supply. Remove cap and clean.
Poor or sluggish flush.	<ol style="list-style-type: none"> a. Bowl water level too low. b. Supply valve partially closed. c. Partially clogged trapway and/or drain pipe and/or vent. d. Supply pressure too low. 	<ol style="list-style-type: none"> a. Check that refill tube is connected to water control and inserted into tank overflow without being kinked or damaged. b. Open supply valve fully. Be sure that proper supply tube size is used. c. Remove obstruction. Consult a plumber if necessary. d. Normal supply pressure must be at least 20 psi.
Toilet leaks.	<ol style="list-style-type: none"> a. Poor bowl to floor connection. 	<ol style="list-style-type: none"> a. Review steps 1 through 5 of installation instructions.
Toilet does not shut off.	<ol style="list-style-type: none"> a. Flush valve chain too tight, holding flapper open. b. Flush valve seat and/or flapper worn or deformed. c. Sand or debris lodged in water control. 	<ol style="list-style-type: none"> a. Readjust chain length as needed. b. Replace flapper/flush valve assembly, as needed. c. Shut off water supply. Remove cap and clean.

CLEANING INSTRUCTIONS

A mild detergent, warm water and a soft cloth will remove normal dirt and soap accumulations from surfaces. Soft abrasive cleaners may be used on vitreous china. Never use abrasive cleaners without water. Do not use caustic cleaners or disinfectants as they can alter the surface finish and void the warranty.

Use toilet bowl cleaners on the inside of the bowl only. Remove any splashes of cleaner solution from plastic or plated surfaces immediately.

Do not use in-tank cleaners as they can seriously damage the fittings in the tank. This damage could cause leakage and result in property damage. Crosswater London shall not be responsible or liable for any damage that occurs as a result of the use of in-tank cleaners.

Do not allow certain materials such as toothpaste, cologne, shaving cream, nail polish remover, vinegar, wine, drain and glass cleaners to remain on the surface. Prolonged contact can alter surface finishes and void the warranty.

CARE OF TOILET SEATS

Use a soft, damp cloth and a mild soap such as dishwashing liquid to clean the seat. Rinse the seat and dry with a soft towel.

Do not use abrasive cleaners as they will scratch and dull the surface. Do not allow cosmetics or abrasive chemicals to come in contact with the toilet seat.

Soft Close, Quick Release Solid Molded Seat

US-SEATU2

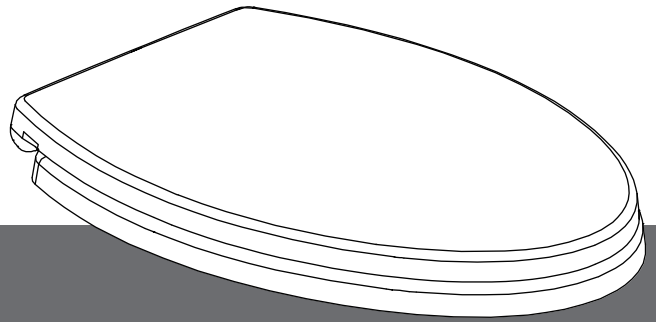

Installation Instructions

Introduction

IMPORTANT: Please read these instructions carefully before you begin and retain for future reference. These instructions have been prepared for your guidance, you must exercise due care at all times.

We do not accept responsibility for any problems that may occur through incorrect installation.

Installation notes

Before installation, please check that all parts have been supplied and are undamaged.

All the fittings shown are workable for installation.

Parts supplied

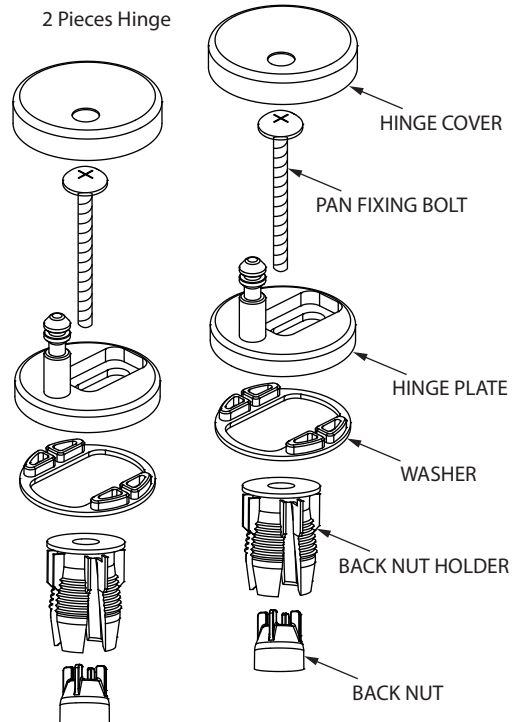
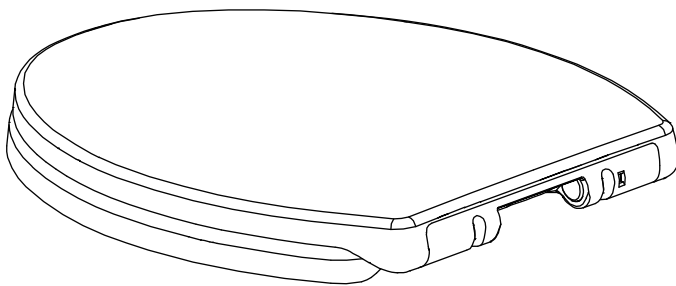

Tools required

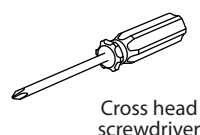
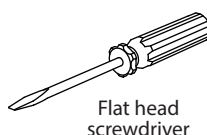

Installation

1

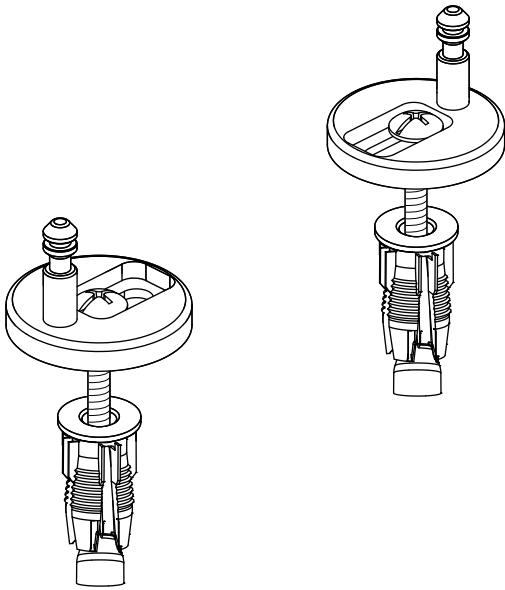

2

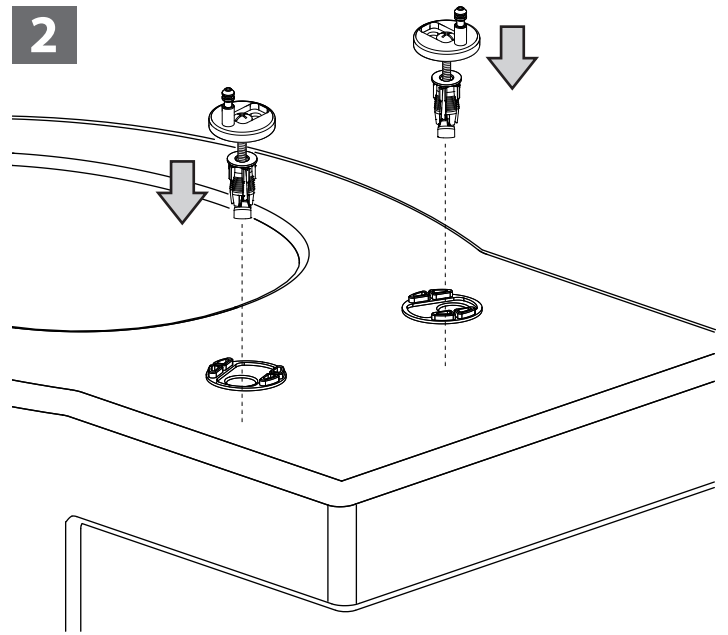

3

DO NOT over tighten.

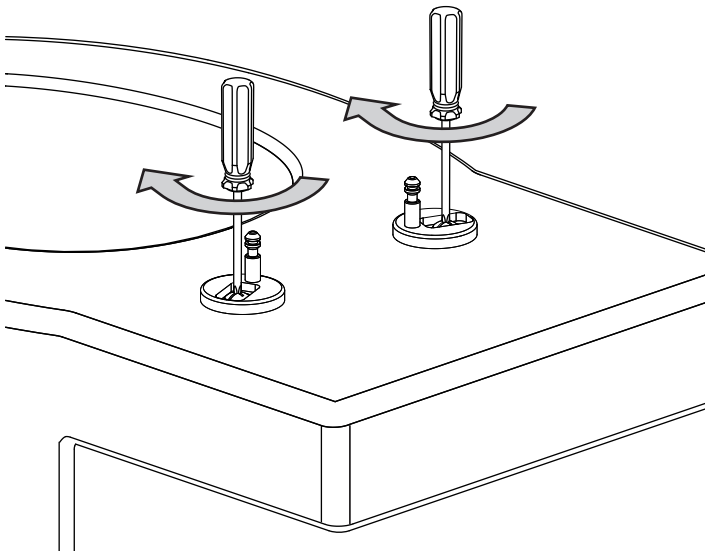

4

Before attaching the seat, move the mounting base so that the posts align with holes in the back of the seat. Once aligned, carefully lower the seat (holes) onto the mounting post.

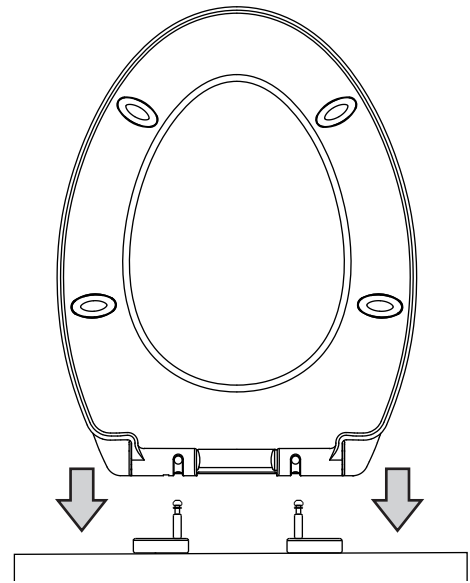

5

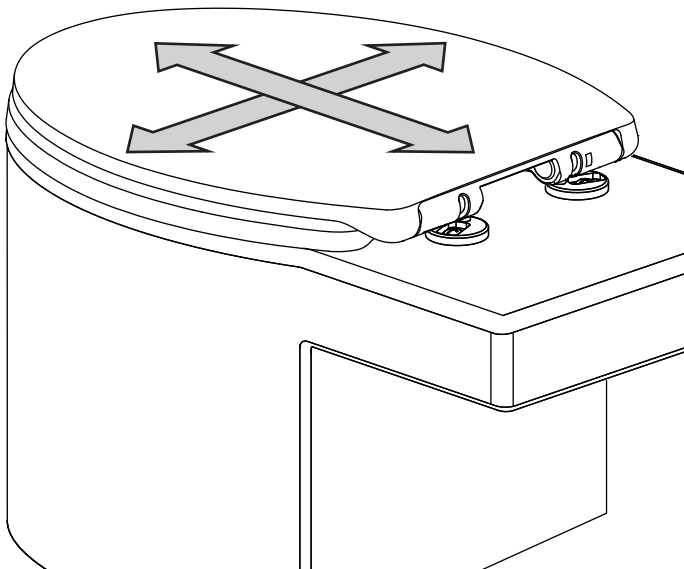

6

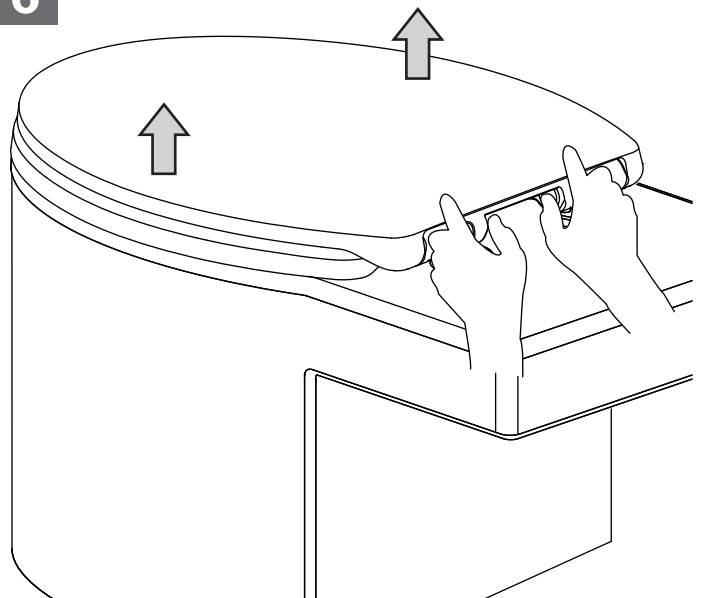

Installation

7 Once satisfied with the position, fully tighten the screws.

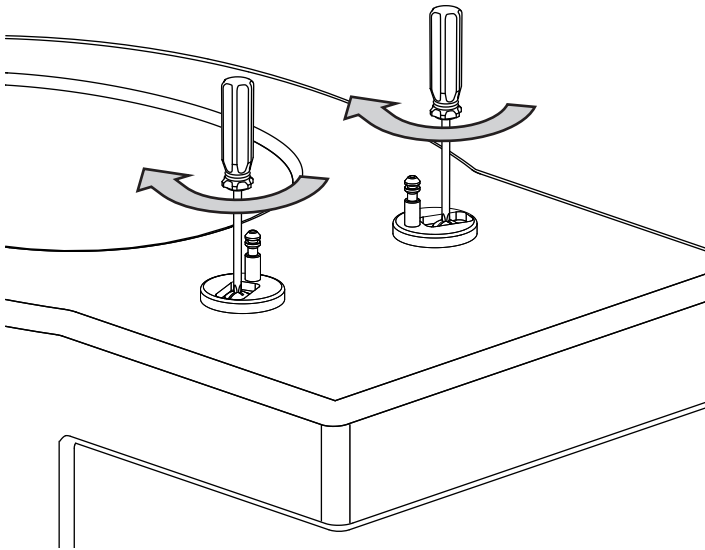

8

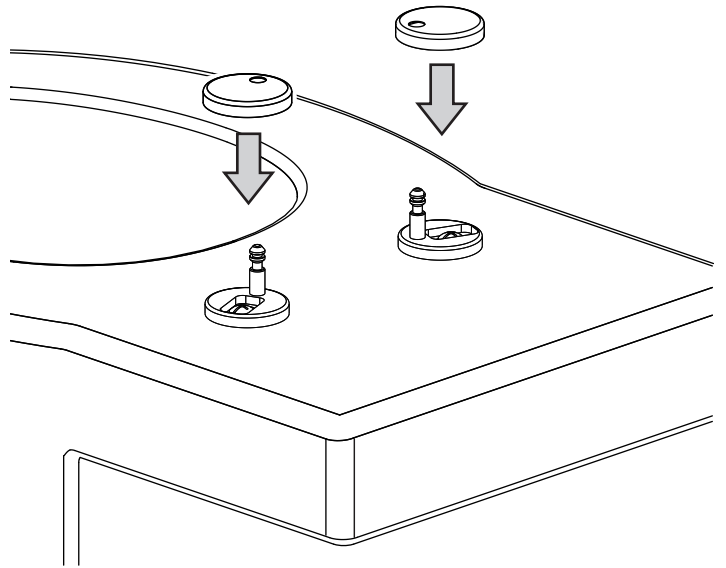

9 When mounting the seat make sure the posts align with holes in the back of seat. And carefully lower seat back into place ("click" will heard).

NOTE: Do not push hard or force seat onto posts. (If difficult, re-check alignment.)

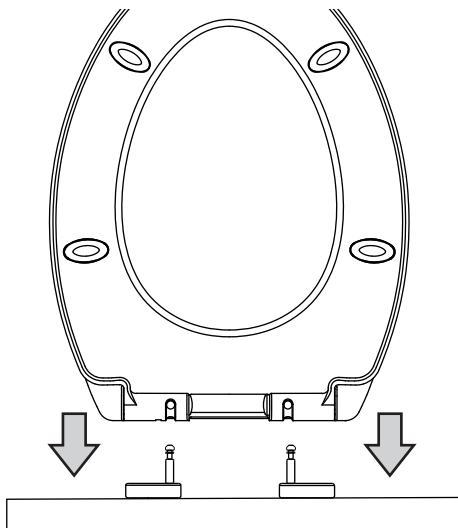

10 To remove the seat, press the quick release button (you should hear a "click")

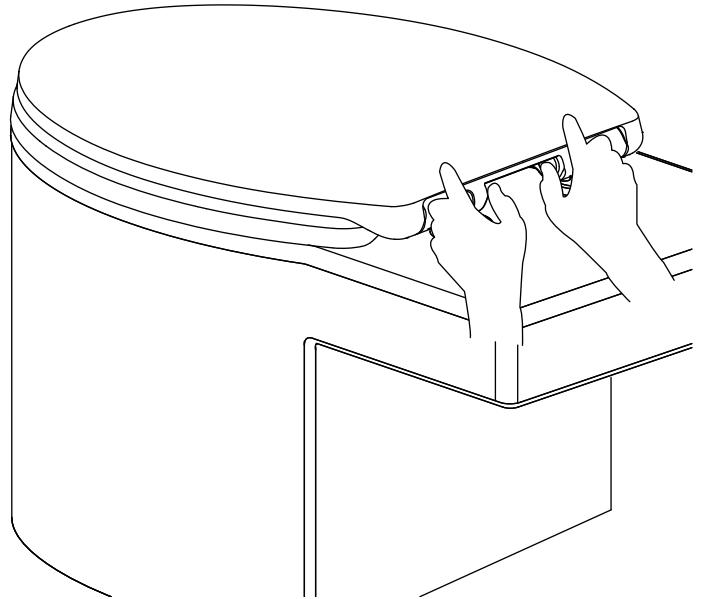

11 Then open seat to the vertical position, then lift the seat straight up with one hand.

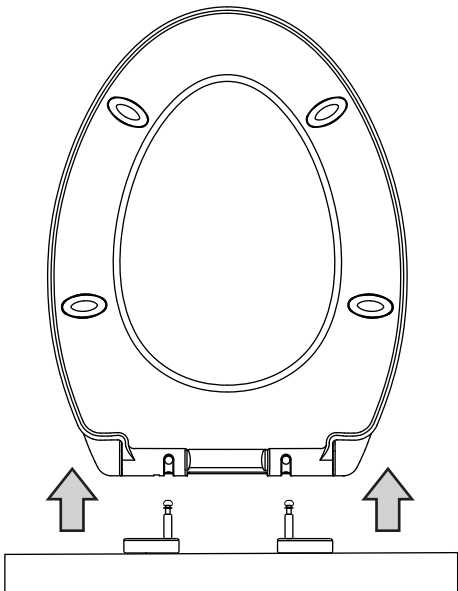

12 Cleaning Instructions

Use a soft, damp cloth and a mild soap such as dishwashing liquid to clean the seat. Rinse the seat and dry with a soft towel. Do not use abrasive cleaners as they will scratch and dull the surface. Do not allow cosmetics or abrasive chemicals to come in contact with the toilet seat.

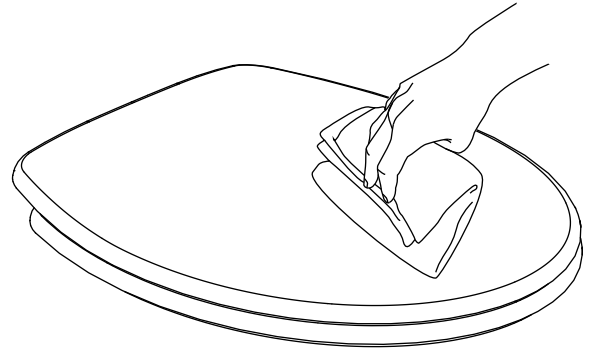

Warranty - Crosswater London toilet seats are covered by a one-year warranty. For full details, terms and conditions please visit our website.

For further information contact: **Crosswater London**, 393 Fortune Blvd., Milford, MA 01757

www.crosswaterlondon.com

Toll free number: 844-XWATER-1 (844-992-8371) tel: 508-381-0433 fax: 508-381-6068

email: technical@crosswaterlondon.com

Issue date: 11152023