

Floor-mount Tub Filler Rough US-399ROUGH

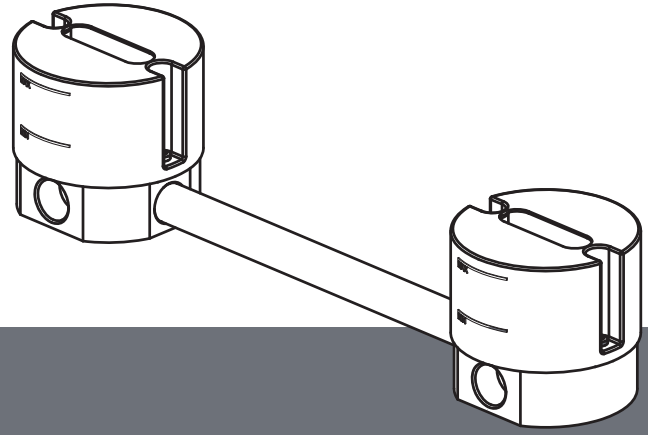

Installation Instructions



Introduction

The faucets in this range are single flow (hot and cold water mix in the body) and should therefore be supplied with hot and cold water at balanced pressures. If the faucets are not supplied at balanced pressures then the mixer will not function correctly.

The minimum water pressure required for these faucets is 20 psi. The maximum water pressure is 60 psi, beyond which pressure-reducing valves must be installed.

IMPORTANT: Please read these instructions carefully before beginning and retain for future reference. These instructions have been prepared for your guidance; you must exercise due care at all times.

We do not accept responsibility for any problems that may occur through incorrect installation.

Installation notes

The installation must comply with all plumbing codes including local codes and be installed by a licensed plumbing contractor.

WARNING! Before installing a new faucet it is essential that the supply pipes are thoroughly flushed in order to remove any remaining debris, solder or other impurities. Failure to carry out this simple procedure can cause problems or damage to the working of the faucet. If soldering any connections, remove the cartridge to prevent damage to the seals and internal assembly.

Installing shut-off valves on incoming supply lines is recommended for ease of maintenance.

It is recommended that the trim to this rough be on site at the time of beginning rough-in installation.

IMPORTANT: Turn off the main water supply before connecting to any existing pipework or doing any maintenance.

WARNING! Please check for any hidden pipes and cables, electric or otherwise, before drilling holes in a wall or floor.

Roughing-in dimensions

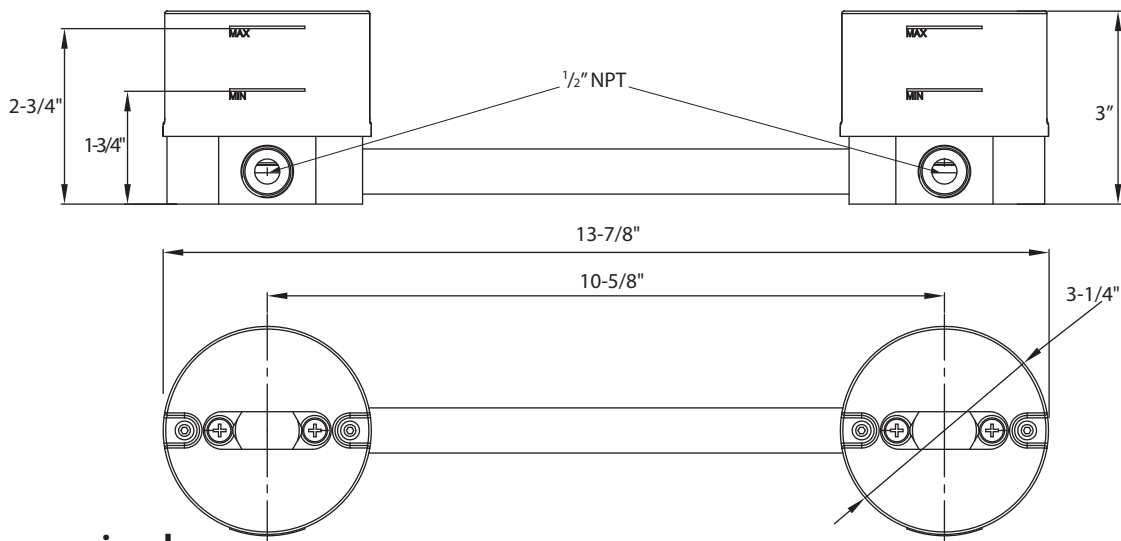

Tools required

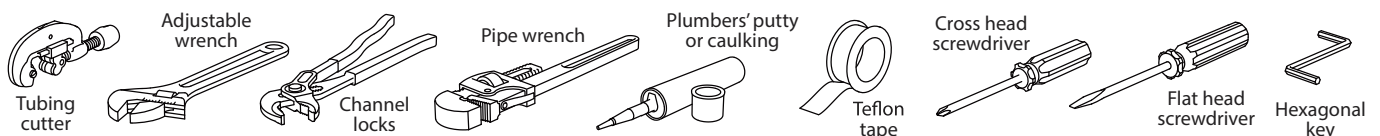

1 Installation

- Shut off the water heating system then, with the main water supply **turned off**, open the lowest hot and cold faucets and allow to drain until supply pipes are empty.

- Prepare the floor by making a cavity ranging from 1-³/₄" to 2-³/₄" in depth within a solid floor.

OR

- Prepare the floor by securing supporting battens ranging from 1-³/₄" to 2-³/₄" in depth within the floor cavity.
- Ensure the supporting battens are suitable to take the weight and fixing method of the valve.
- Secure the valve body using the anchor bolts supplied.

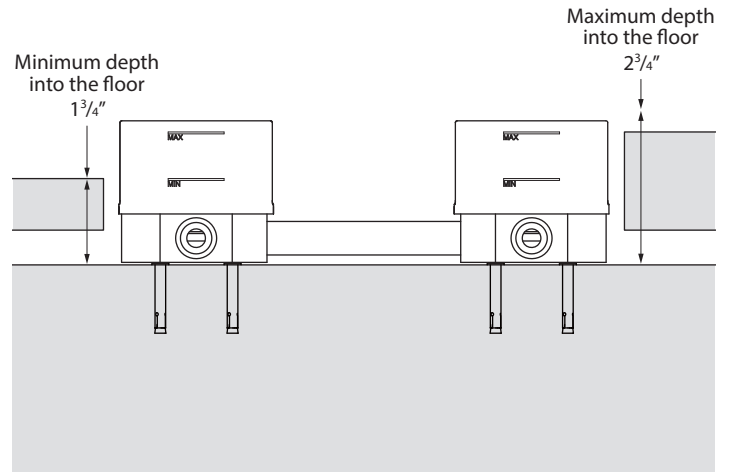

2 Installation

- Connect the **hot** and **cold** water supplies to the 1/2" NPT fittings at the bottom of the valve body using compression fittings and washers supplied.
- Turn on the main water supply and check for leaks.
- **Do not** remove the plastic covers until all of the checks have been completed.
- Once satisfied there are no leaks **turn off** the main water supply.

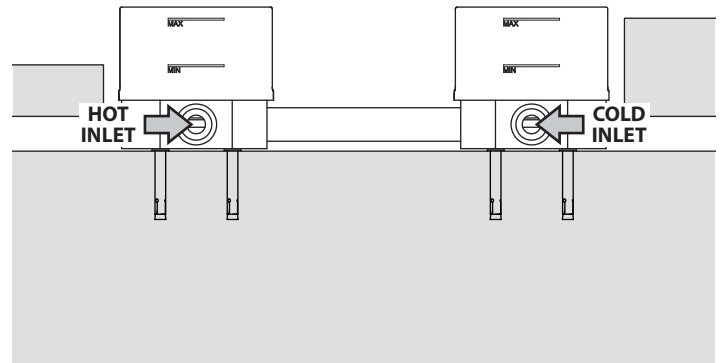

3 Installation

- Continue the installation by following the installation instructions for the chosen trim.
- **Do not** turn on the main water supply until the installation is complete

Parts list

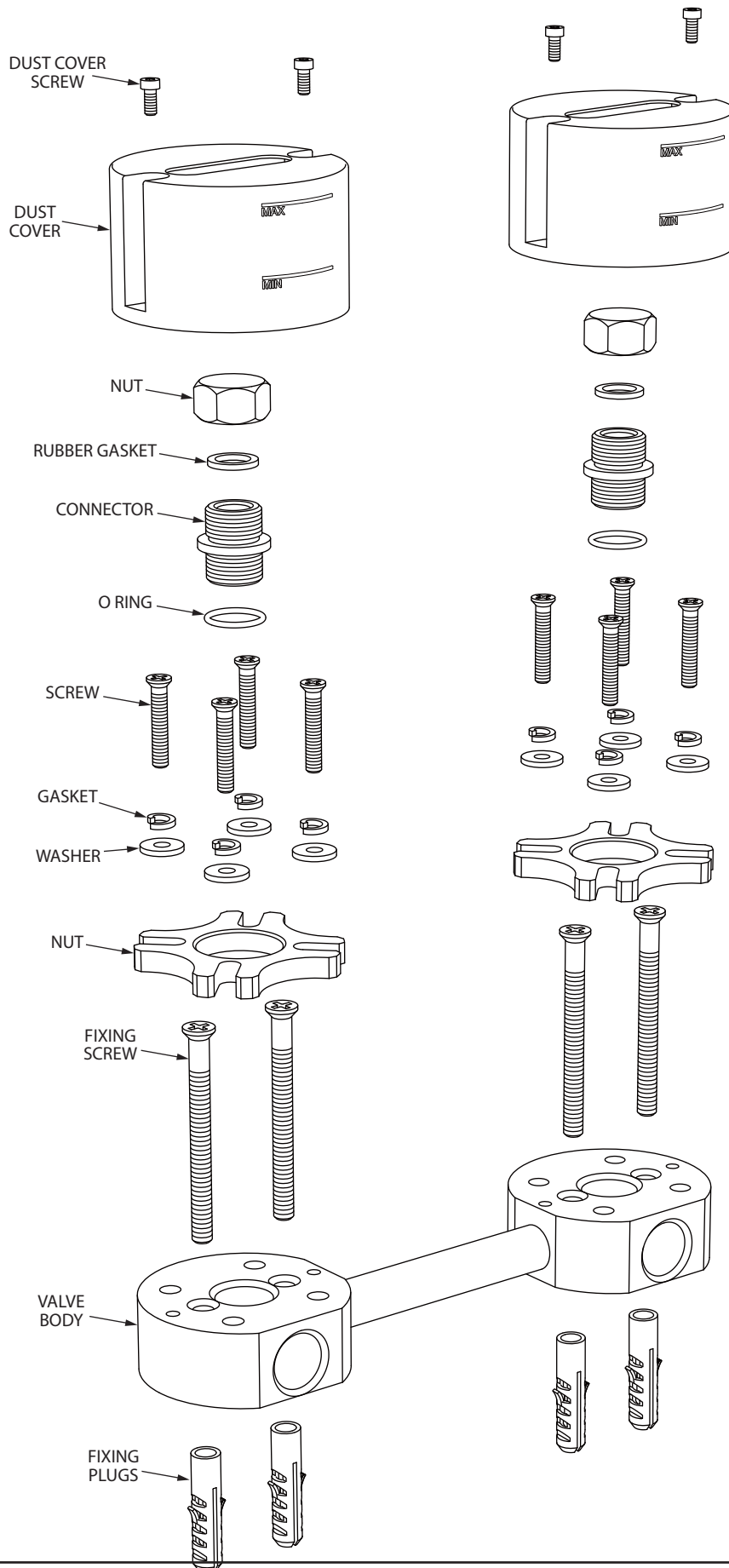

Warranty - This **Crosswater London** product is covered by a limited lifetime warranty. For full details, terms and conditions please visit our website. For further information contact: **Crosswater London**, 393 Fortune Blvd., Milford, MA 01757 www.crosswaterlondon.com
 Toll free number: 844-XWATER-1 (844-992-8371) tel: 508-381-0433 fax: 508-381-6068 email: technical@crosswaterlondon.com