

Replacement Parts

NO.	Description	Part No.
1	Stop Valve	9Q1152NT
2	Pressure Balance Cartridge	5D0M0262PL
3	Stem & Threaded Nipple	9Q1173NT

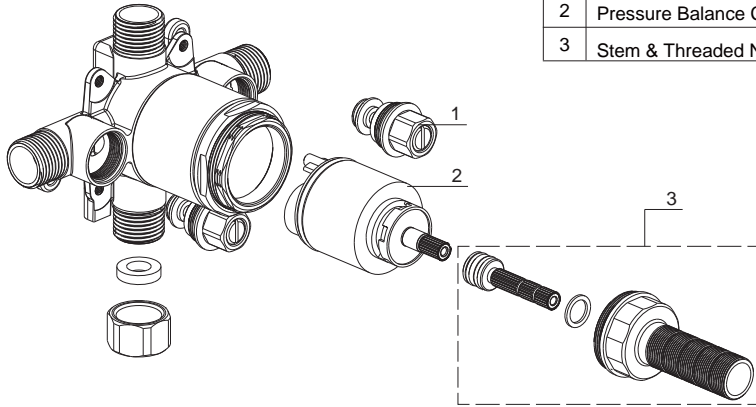

Applicable Standards/Codes

IAPMO certified to meet or exceed the following:

- ASME A112.18.1/CSA B125.1
- Uniform Plumbing Code
- National Plumbing Code of Canada
- ASSE 1016



Installation Dimensions

Note: The UNION range of trim plates require an opening no larger than 5".

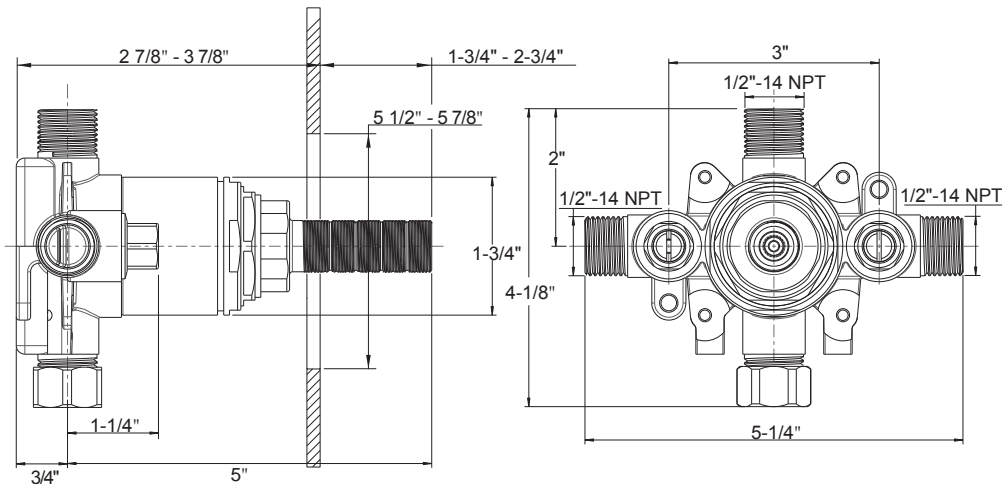

Pressure-balance Valve Rough
PBS-RGH

Installation Instructions



For ease of installation you will need:

- To read all the installation completely before beginning.
- To read all warnings, care, and maintenance information.

Before beginning installation, check for any damage that may have occurred during transport.

Note: Damage claims cannot be made during or after installation.

Installation Instructions

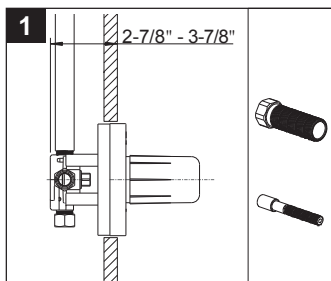

This valve is designed to fit into a wall that is 2-7/8" to 3-7/8" from finished wall to the back of the valve. Extensions are available separately if necessary.

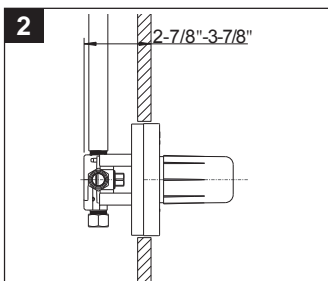

Turn off the water supplies. Install the valve so the finished wall will fit between the markers on the mud guard.

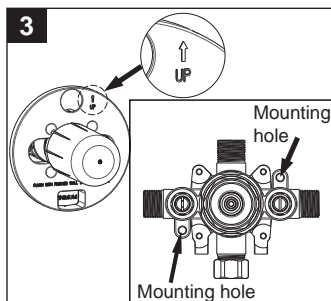

Using mounting holes secure the valve making sure the "UP" label outlet is on top.

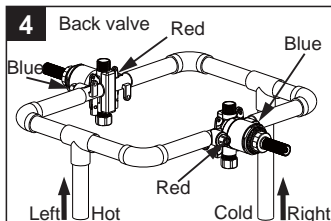

If you are making a back-to-back installation (hot on right and cold on the left), install the back valve body as described in steps #5 – #6. If not, go to step #7. NOTE: Notice that the back valve has hot and cold indicators that will be opposite of the incoming supply lines.

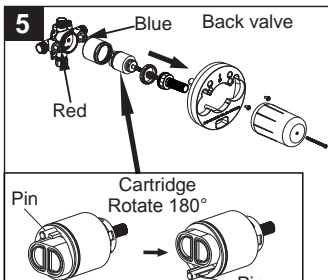

Remove the cartridge and stem assembly. Notice that the pin is at the top. Rotate the cartridge 180°. The pin should be on the bottom.

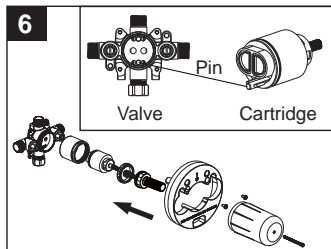

Align the pins on the bottom of the cartridge and push the cartridge into the valve. Make sure the cartridge is firmly installed into the valve body. Reinstall stem assembly with mud guard.

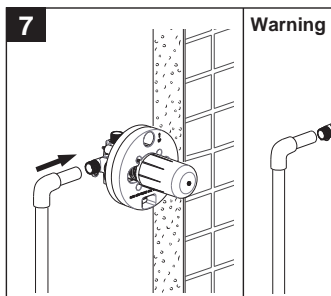

Warning

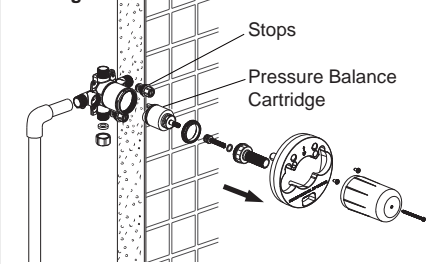

Connect valve body to water supplies using the proper fittings. Warning: avoid soldering at high temperature. Exposure to high temperature may damage the cartridge. Be sure stops and pressure balance cartridge are removed before soldering.

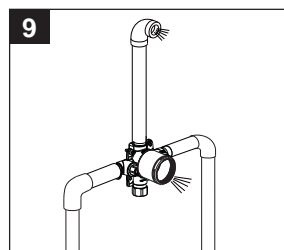

Flush the system

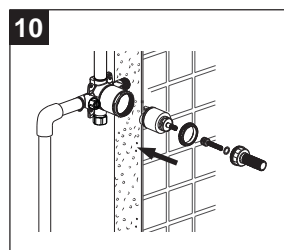

Reinstall cartridge assembly and stop assembly to the valve body.

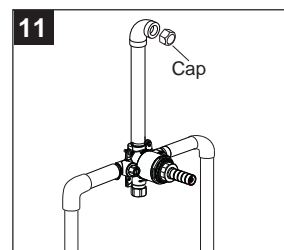

Pressure test and check for leaks.

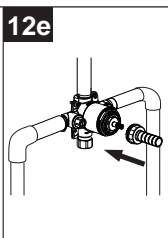
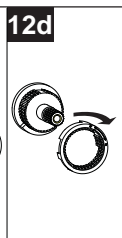
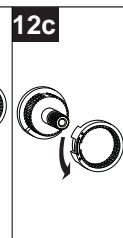
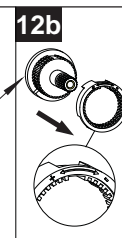
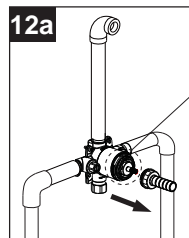

Temperature Adjustment:

- a: Remove the stem assembly.
- b: Remove the spacing collar.
- c: Rotate the spacing collar to adjust hottest temperature. Rotate clockwise to reduce temperature.
- d: Rotate counterclockwise to increase temperature.
- e: Reinstall the stem assembly.

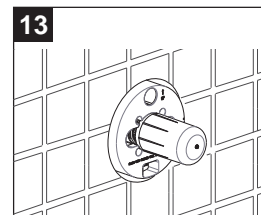

Installation completed.

IMPORTANT: DO NOT use the mud guard as a tile guide.

It is the responsibility of the installer to ensure that the hole is the correct size for the trim plate.

Warranty - This Crosswater London product is covered by a limited lifetime warranty. For full details, terms and conditions please visit our website. For further information contact: **Crosswater London**, 393 Fortune Blvd., Milford, MA 01757 Toll free number: 844-XWATER-1 (844-992-8371) tel: 508-381- 0433 fax: 508-381-6068 www.crosswaterlondon.com email: technical@crosswaterlondon.com