

# MPRO Wall-mount Widespread Basin Faucet Trim

US-PRO130-2

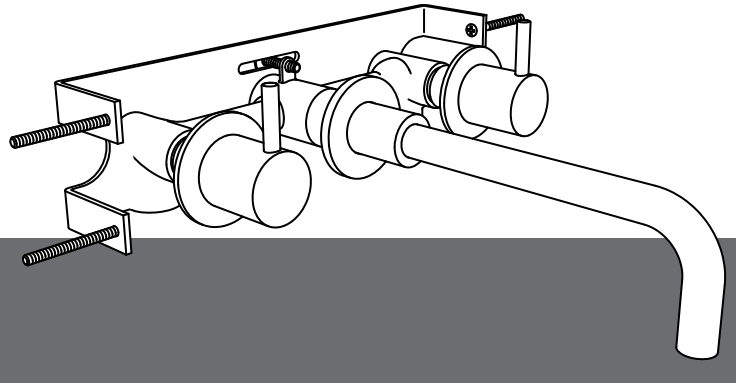

## Installation Instructions



### Introduction

The faucets in this range are single flow (hot and cold water mix in the body) and should therefore be supplied with hot and cold water at balanced pressures. If the faucets are not supplied at balanced pressures then the mixer will not function correctly.

The minimum water pressure required for these faucets is 20 psi. The maximum water pressure is 60 psi beyond which pressure-reducing valves must be installed.

The faucets are fitted with quarter-turn ceramic disc cartridges which provide a good flow rate with very smooth movement.

**IMPORTANT: Please read these instructions carefully before you begin and retain for future reference. These instructions have been prepared for your guidance, you must exercise due care at all times.**

Before beginning installation, check for any damage that may have occurred during transport. **Note: Damage claims cannot be made during or after installation.**

**We do not accept responsibility for any problems that may occur through incorrect installation.**

### Installation notes

The installation must comply with all plumbing codes including local codes and be installed by a licensed plumbing contractor.

**Install the US-130ROUGH-2 first using the installation instructions provided with it before following the trim installation detailed below.**

**WARNING!** Before installing a new faucet it is essential that the supply pipes are thoroughly flushed in order to remove any remaining debris, solder or other impurities. Failure to carry out this simple procedure can cause problems or damage to the working of the faucet.

Installing shut-off valves on incoming supply lines is recommended for ease of maintenance.

**Turn off the main water supply before connecting to any existing pipework or doing any maintenance.**

**WARNING! Please check for any hidden pipes and cables, electric or otherwise, before drilling holes in a wall or floor.**

### Dimensions

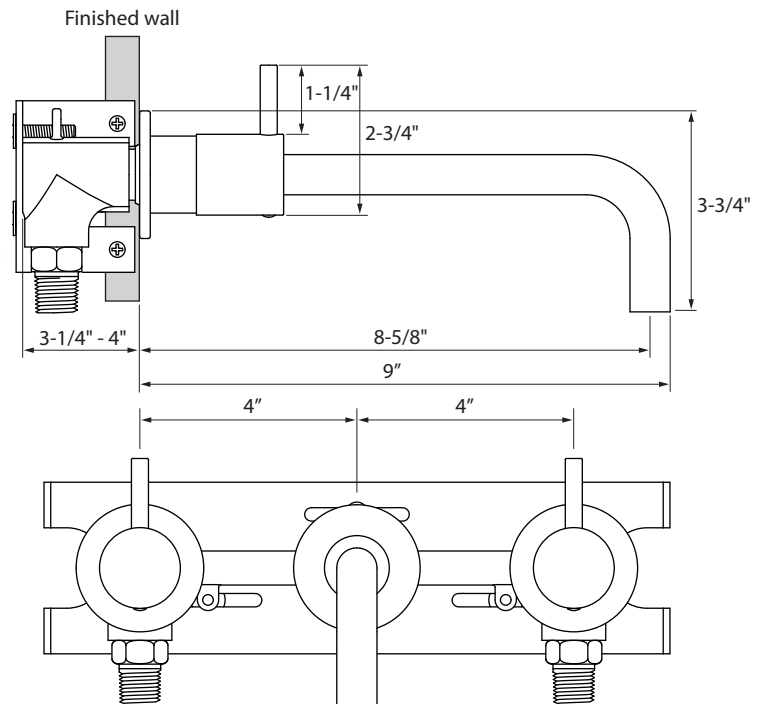

### Flow rate

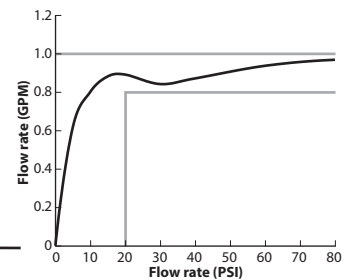

### Tools required

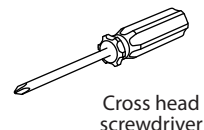
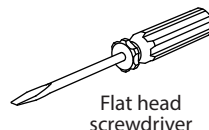
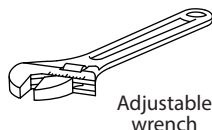
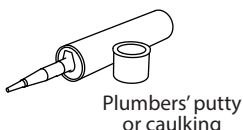
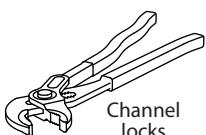

# 1 Installation

● Shut off the water heating system then, with the main water supply **turned off**, open the lowest hot and cold faucets and allow to drain until supply pipes are empty.

Install the **US-130ROUGH-2** first, using the installation instructions provided with it, before following the trim installation detailed below.

## Spout

- Apply a narrow bead of silicone to the back edge of the cover plate and place around the main outlet.
- Attach the spout and tighten until spout is vertical.
- Use teflon tape to achieve a watertight seal.

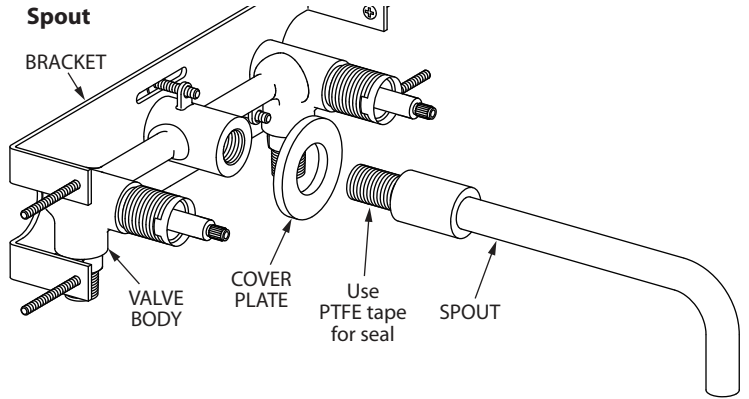

## Sleeve

- Install the sleeve by sliding it over the spindle and secure with the retained long cover screws.

## Handle

- Apply narrow bead of silicone to the back edge of the collar and press into position.
- Place the handles onto the sleeve and secure using a hexagonal key.
- Push fit the cover caps.

### ATTENTION: Check all new connections for leaks.

- Turn on the main water supply, close all faucets except the new mixer and as the system refills, check for leaks.
- Once satisfied there are no leaks, switch on the heating system.

## Sleeve

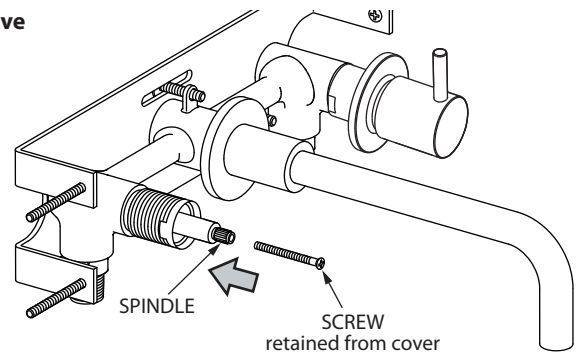

## Handle

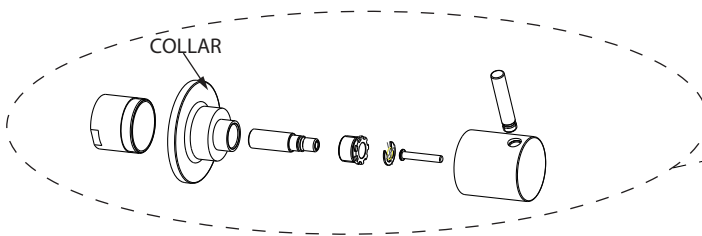
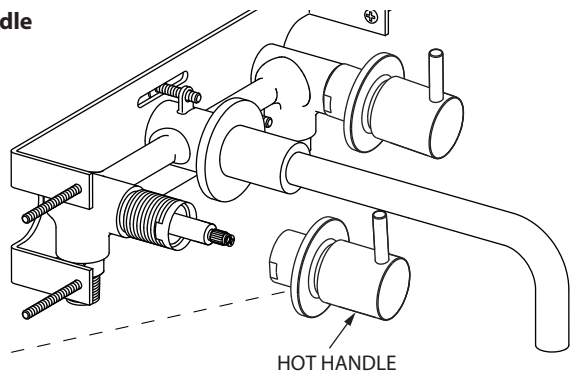

## 2 Maintenance

### Cleaning the flow cartridge

- The concealed flow cartridge should give trouble-free service however servicing is a straightforward process.

### To remove the flow cartridge

- With the water supply **turned off**, carefully remove the cover cap and using a hexagonal key loosen the screw but do not remove.
- Pull off the handle and unscrew the collar.
- Using a 7/8" wrench, unscrew and remove the flow cartridge.
- Wash the flow cartridge with clean running water, dry and lightly grease the seal, (only use silicone grease).
- Replace the flow cartridge followed by the nut, collar and handle.

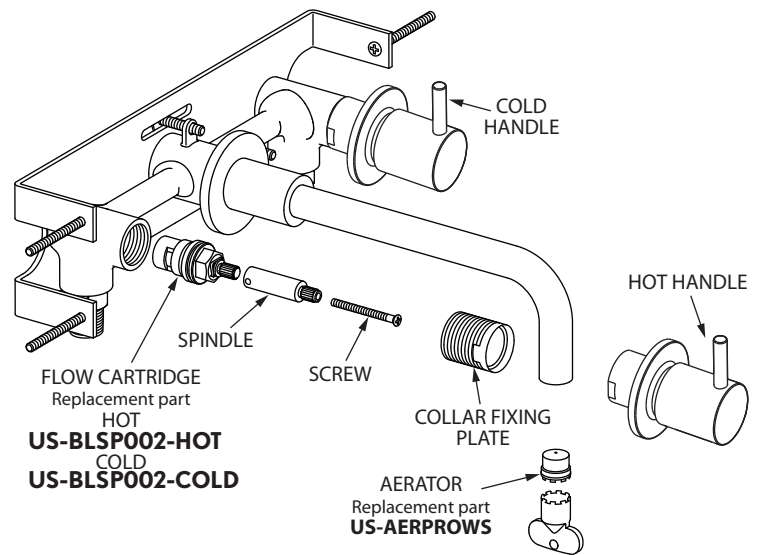

## 3 Cleaning Instructions

Rinse away any traces of soap and gently dry with a clean, soft cloth after each use. Rinse completely with water and dry any overspray. This will maintain the finish and avoid water spotting.

To remove mineral deposits, use a 50/50 solution of white vinegar and water. Do not allow the solution to soak on the product. Simichrome Polish® contains a protective film to enhance maintenance and is helpful in preventing water spot buildup. Follow instructions to ensure optimum results.

Never use an abrasive material such as a brush or scouring pad to clean the surface. The use of abrasive cleaners, cleansers or disinfectants will alter the surface finish and void the warranty.

Do not allow certain materials such as toothpaste, cologne, shaving cream, nail polish remover, vinegar, wine, drain and glass cleaners to remain on the surface. Prolonged contact will alter surface finishes and void the warranty.

**We DO NOT recommend using any household cleaners as many can cause damage to the finish.**

Please see the website for care instructions for specific finishes.

**Warranty** - This **Crosswater London** product is covered by a limited lifetime warranty. For full details, terms and conditions please visit our website.

For further information contact: **Crosswater London**, 393 Fortune Blvd., Milford, MA 01757

[www.crosswaterlondon.com](http://www.crosswaterlondon.com)

Toll free number: 844-XWATER-1 (844-992-8371) tel: 508-381-0433 fax: 508-381-6068

email: [technical@crosswaterlondon.com](mailto:technical@crosswaterlondon.com)